

Mazak

FJV 5 Face SERIES

FJV 5 Face
S E R I E S

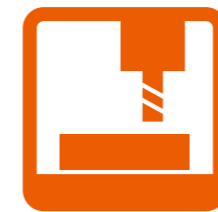

35/60

35/80

35/120

60/80

60/120

60/160

100/120

100/160

YAMAZAKI MAZAK CORPORATION

1-131 Takeda, Oguchi-cho, Niwa-gun, Aichi-pref., Japan
TEL : +(81)587-95-1131 FAX : +(81)587-95-2717

www.mazak.com

- Specifications are subject to change without notice.
- This product is subject to all applicable export control laws and regulations.
- The accuracy data and other data presented in this catalogue were obtained under specific conditions. They may not be duplicated under different conditions. (room temperature, workpiece materials, tool material, cutting conditions, etc.)



Mazak

Advanced features of the MAZATROL SmoothG CNC

Touch screen operation—Operates similar to your smart phone / tablet

PC with Windows® 8 embedded OS

Fastest CNC in the world—Latest hardware and software for unprecedented speed and precision

Easy conversational programming

Smooth graphical user interface and support functions for unsurpassed ease of operation

Fine tuning functions—Easily configure machine parameters for different workpiece materials and application requirements

MTConnect® ready—Convenient networking

Windows is a registered trademark of Microsoft Corporation in the United States and other countries. MTConnect is a registered trademark of AMT in the United States and other countries.



MAZATROL SMOOTHG



Machine top and side surfaces in a single workpiece setup

The FJV 5 Face series is designed for high efficiency and high precision performance - incorporating "MAZAK 5 Face Angle Head" for increased versatility

FJV 5 Face-35/60



Shown with optional equipment

5-Face high accuracy double column vertical machining center

FJV 5 Face SERIES

MAZAK 5 Face Angle Head

Continuous 4 side machining

FJV 5 Face-100/160



Shown with optional equipment

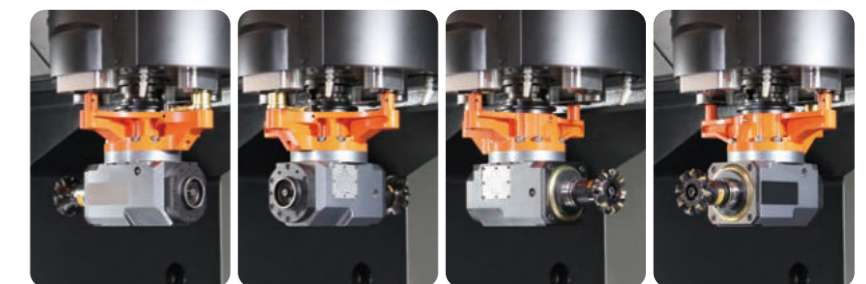

0°

90°

180°

270°

Higher Productivity

5 Face machining system

MAZAK 5 Face Angle Head

Four face machining with one angle tool

The MAZAK angle head is tightly clamped by the unique MAZAK four hydraulic clamping units on the spindle housing surface. The angle head can be indexed to four positions, every 90°, to minimize the number of required tools.

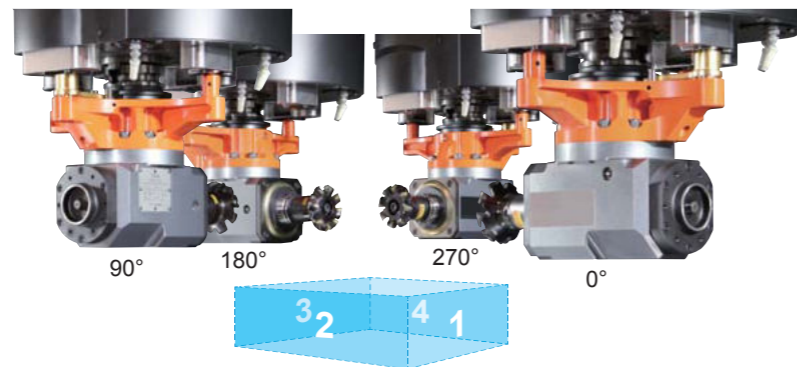

High efficiency cutting of 4 side surfaces

Unlike conventional angle tools, the angle head is strongly clamped by three of the clamping units. Heavy-duty cutting can be performed thanks to this rigid construction.

Wide angle head cutting range

Compact angle head reduces interference with workpiece for large machining area.

- Max. speed : **2000 rpm**
- Max. input power : **12 kW (16 HP)**
- Material removal rate : **418 cc/min**

(Workpiece material : S45C)

| | | |
|--------------------|----------------------|---------------|
| Cutting conditions | Depth of cut | 5 mm |
| | Feedrate (per tooth) | 0.30 mm/tooth |
| | Cutting width | 70 mm |

| | | |
|--------------|-----------------|-----------------|
| Cutting tool | Tool dia. | Φ100 mm |
| | Number of teeth | 5 teeth |
| | Holder type | A63-FMA31.75-60 |
| | Tool type | HSG45-5100R |
| | Insert | SGHN1504AZN-44 |

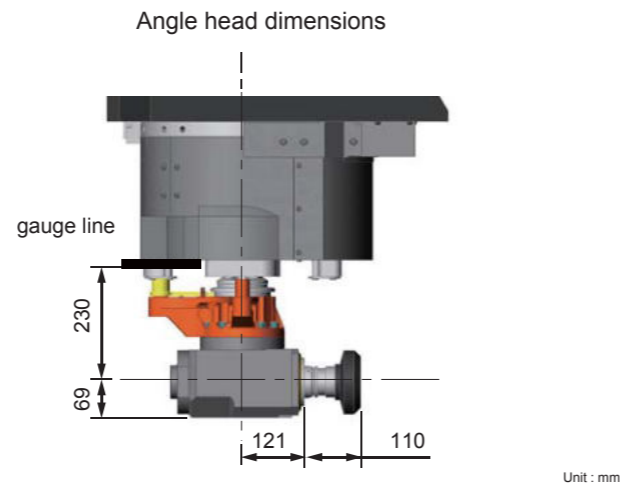

Unit : mm

High-speed Angle Tool Holder OPTION

The high speed angle tool holder has a spindle speed of 5000 rpm for effective machining by small diameter endmills and drills. This tool can be stored in the 60 and 80 tool magazines and automatically loaded / unloaded to / from the spindle.



Tool capacity

- Endmill **Φ5.8 ~ 20 mm**
- Drill **Φ5.8 ~ 20 mm**



Dedicated magazine for angle head tool

Enhanced versatility

The dedicated angle tool magazine has a storage capacity of 8 tools, as a result, multiple angle tools are not required.



- Tool shank : **HSK-A63**
- Capacity : **8 tools**

- Max. tool size (face mill) : **Φ125 mm × 207 mm**
- Max. tool size (drill) : **Φ40 mm × 250 mm**

5 Face Machining

MAZATROL *SMOOTHG*

Simplified programming of machining by angle head

Convenient programming even for 5 face machining

Can be performed by both MAZATROL and EIA programs. Side-surface machining is easily programmed using the conversational MAZATROL format. All that is required is to enter which surface is to be machined followed by normal data entry.

Coordinate system and machining surface

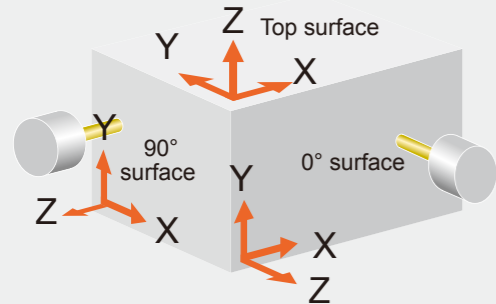

EIA / ISO program format

G-code coordinate conversion is used for EIA / ISO programs.

| G-code for 5 face programming | | |
|-------------------------------|-------------------|-------|
| 5 face machining | Top surface mode | G17.1 |
| | 0° surface mode | G17.2 |
| | 90° surface mode | G17.3 |
| | 180° surface mode | G17.4 |
| | 270° surface mode | G17.5 |
| | Cancel | G17.9 |

Tool data entry for angle head (tool data screen)

Tool data for tools used with the angle head are input the same way as data for other tools.

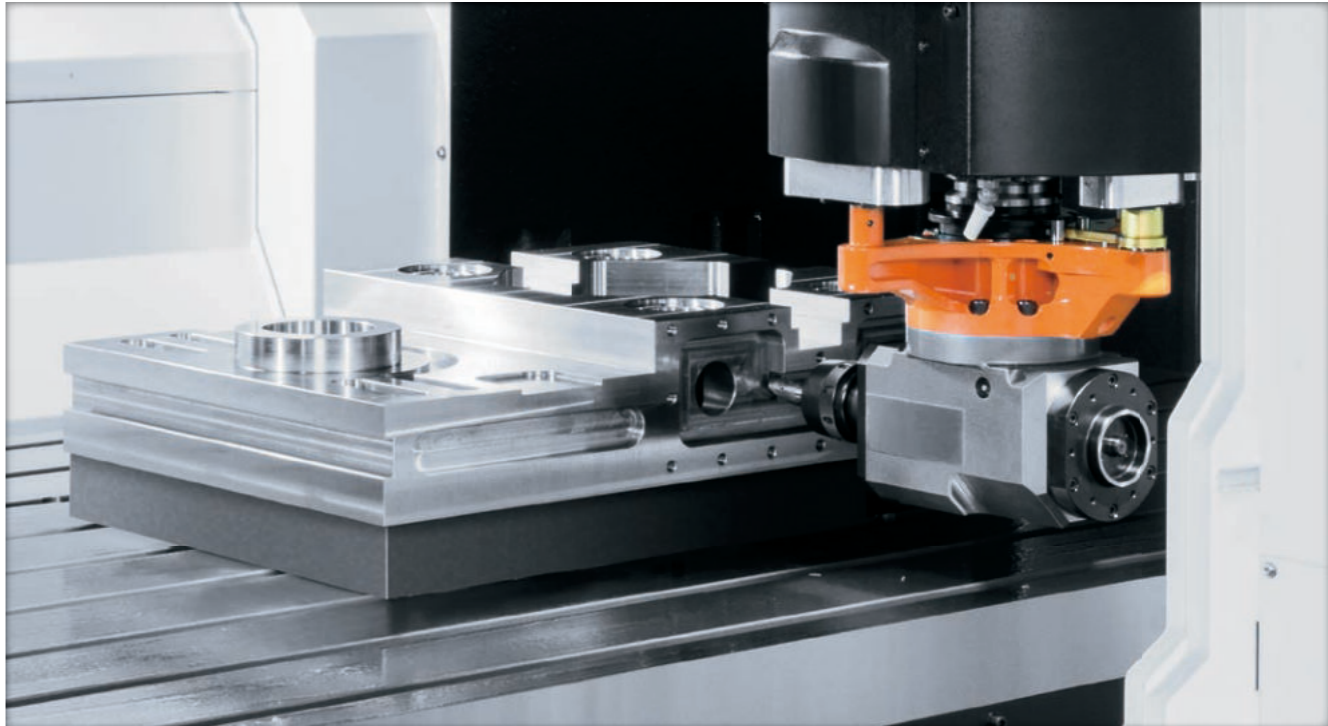
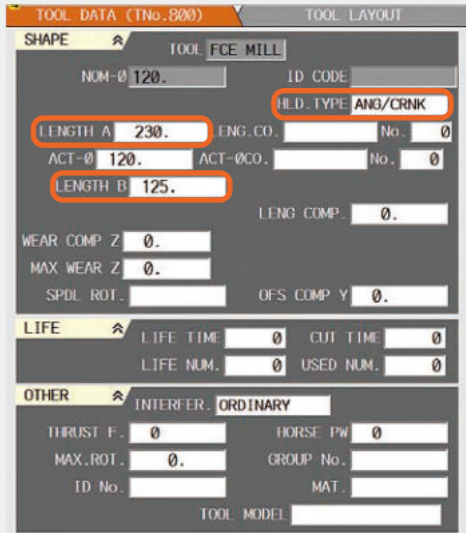
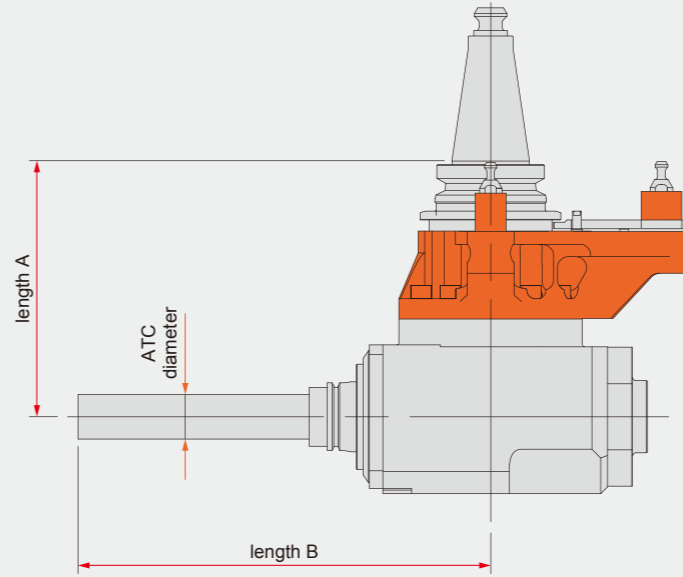

Higher Productivity

Two different spindle specifications available

Thanks to the integral spindle / motor, vibration is minimized during high speed operation to ensure exceptional surface finishes and maximum tool life.



Standard 10000 rpm spindle

The standard 10000 rpm spindle has the speed and power for the machining of a wide variety of workpiece materials, from cast iron and steel to aluminum and other non-ferrous materials.

| | | |
|--------------|--------------------------|---------------|
| Max. speed | | 10000 rpm |
| Motor output | 30 min. rating (40 % ED) | 37 kW (50 HP) |
| | cont. rating | 30 kW (40 HP) |
| Tool shank | | No. 50 |

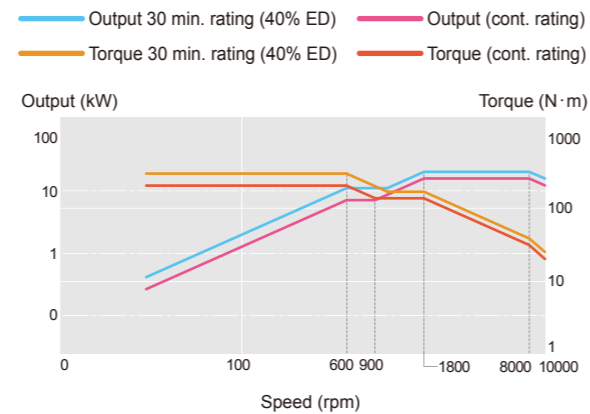

High torque 7000 rpm spindle OPTION

Optional 7000 rpm high torque (442 N·m (30 min. rating)) spindle for the heavy duty machining of steel or cast iron material.

| | | |
|--------------|--------------------------|---------------|
| Max. speed | | 7000 rpm |
| Motor output | 30 min. rating (40 % ED) | 30 kW (40 HP) |
| | cont. rating | 22 kW (30 HP) |
| Tool shank | | No. 50 |

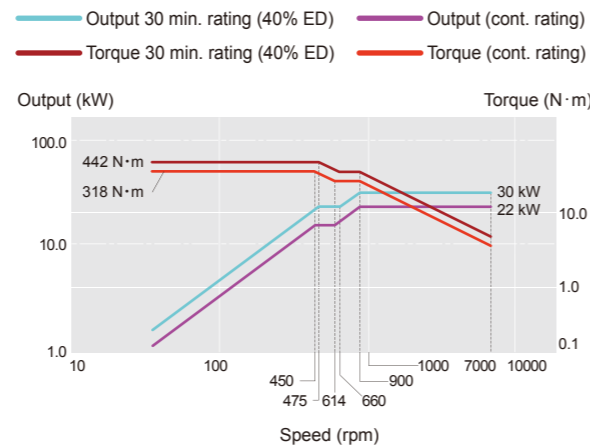

High speed rapid traverse rate

By utilizing linear roller guides on all axes and direct servo driven ball screws, not only is non-cutting time reduced - high accuracy machining is ensured even at high speed feedrates.

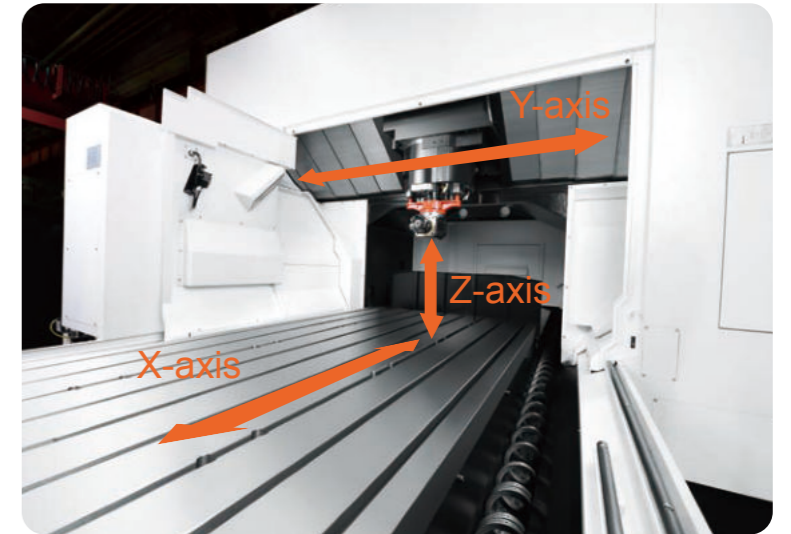

Rapid traverse rate (unit : mm/min)

| Machines | 35/60 | 35/80 | 35/120 | 60/80 | 60/120 | 60/160 | 100/120 | 100/160 |
|----------|-------|-------|--------|-------|--------|--------|---------|---------|
| X-axis | 40000 | 40000 | 32000 | 40000 | 32000 | 22000 | 30000 | 30000 |
| Y-axis | 40000 | 40000 | 40000 | 40000 | 40000 | 40000 | 40000 | 40000 |
| Z-axis | 30000 | 30000 | 30000 | 30000 | 30000 | 30000 | 30000 | 30000 |

Automatic tool changer

Automatic tool changer (max. tool weight : 20 kg) ensures stable operation over extended periods of time. The standard 30 tool magazine is located at the rear of the machine (standard tool magazine for FJV 5 Face-100 is 60 tools).

ATC specifications

| Machines | FJV 5 Face-35 | FJV 5 Face-60 | FJV 5 Face-100 |
|--|---------------|---------------|----------------|
| Tool change time (chip-to-chip) | 5.0 sec. | 6.2 sec. | 8.5 sec. |
| Tool storage capacity | 30 (60*) | 30 (60*) | 60 |
| Max. tool diameter | | Φ125 mm | |
| Max. tool diameter with adjacent pockets empty | | Φ210 mm | |
| Max. tool length | | 380 mm | |
| Max. tool weight | | 20 kg | |

* Option

FJV 5 Face SERIES

5 Face high accuracy
double column
vertical machining center

Wide range of
available machining
envelopes

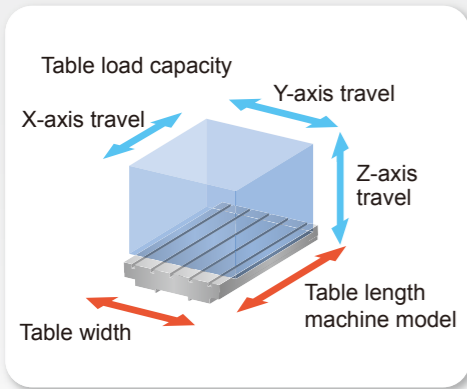

X-axis travel

4200 mm

3200 mm

3000 mm

2000 mm

1500 mm

FJV 5 Face SERIES

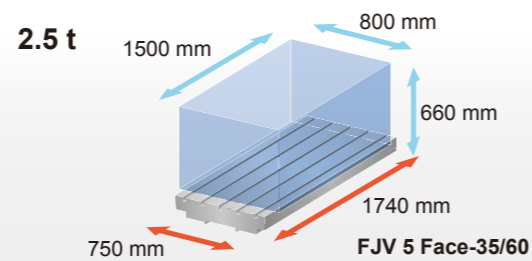
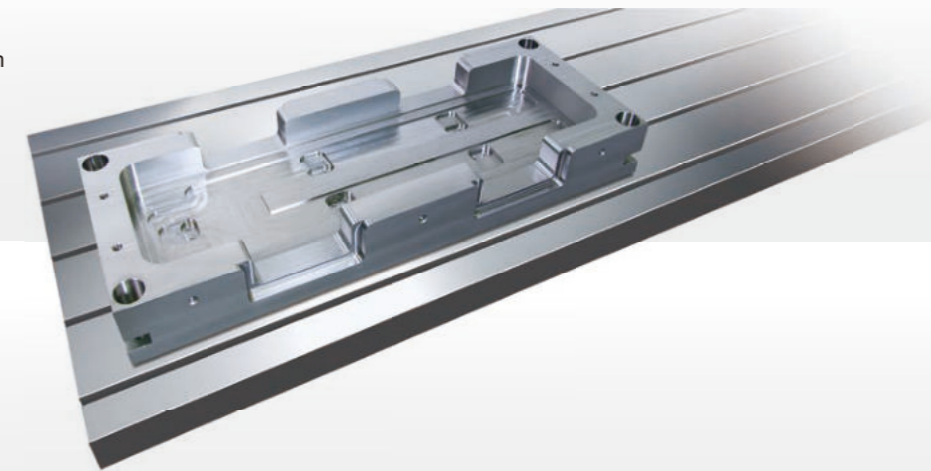
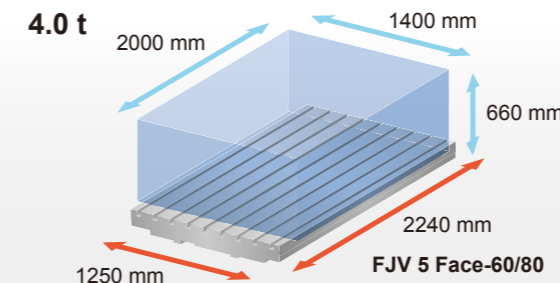
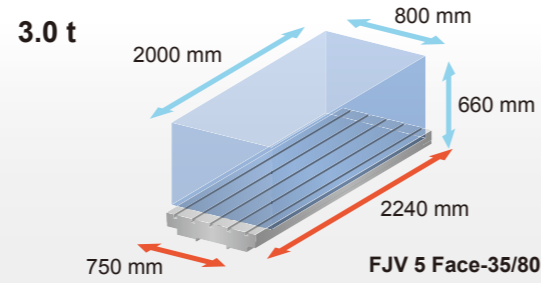
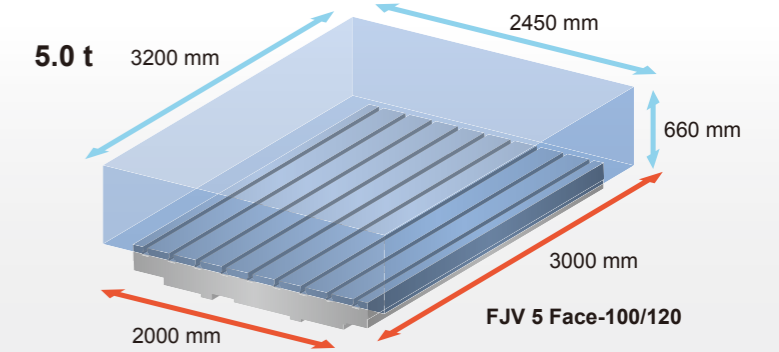
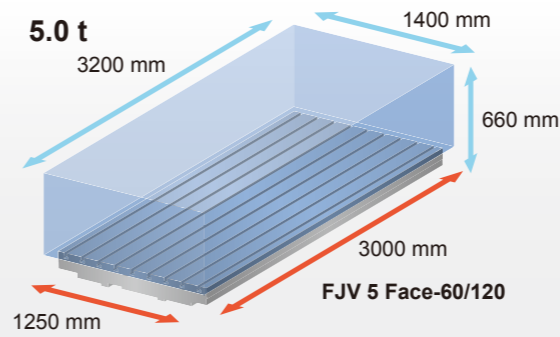
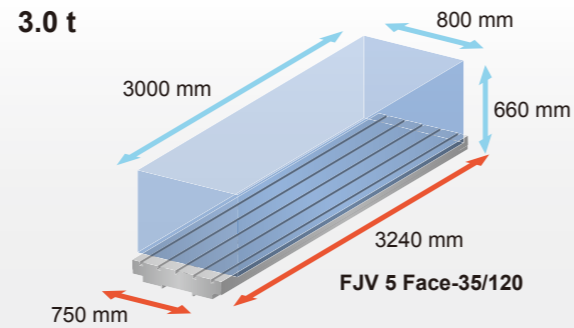
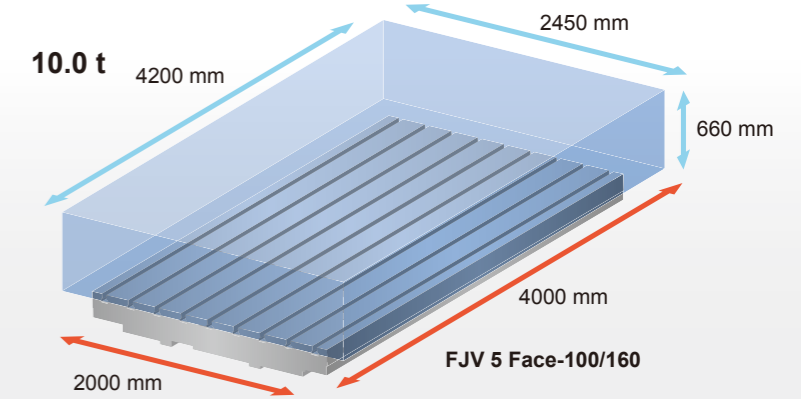
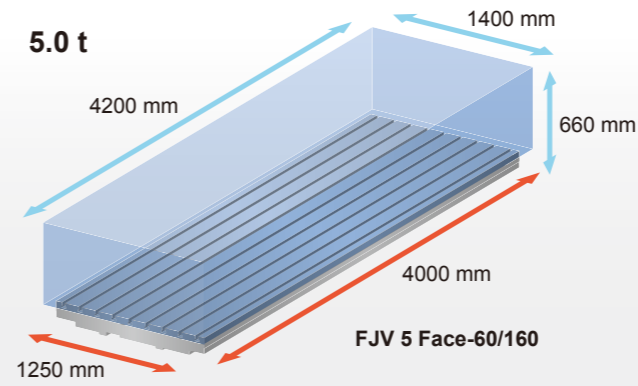

FJV 5 Face-35/60
860 mm



FJV 5 Face-60/80
1500 mm



FJV 5 Face-100/120
2500 mm

Effective width between columns

Higher Accuracy

The symmetrical machine construction together with advanced technologies provide unsurpassed performance

High accuracy machine construction

The high rigidity machine base and column ensure high accuracy over a long service life.

Headstock cooling system

Temperature controlled cooling oil circulates through the outside of the spindle and motor housing to eliminate thermal distortion and ensures high quality machining.

Linear roller guides

The linear roller guides on the X-, Y- and Z-axes utilized by the FJV series provide high accuracy positioning. Additionally, with their high rigidity and considerably lower friction, high speed feedrates can be used over a wide range of machining, from heavy duty to high speed cutting.

Ball screw / servo motor

The X-, Y-, Z-axes ball screws directly connected with the servo motors minimize backlash and provide high accuracy positioning when compared to gear train or timing belt drive.

Ball screw core cooling

Temperature controlled cooling oil circulates through the ball screw cores to ensure stable machining accuracy over extended periods of high speed operation.

Symmetrical machine design

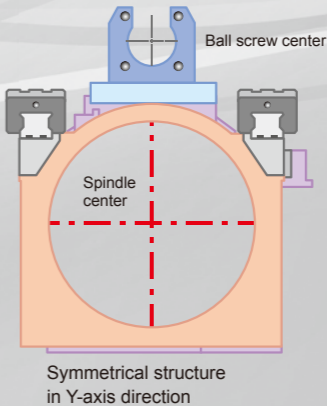

The headstock features symmetrical construction. Since the integral spindle / motor does not utilize a transmission which would have asymmetrical construction, any heat generated by high speed operation will result in uniform thermal displacement of the headstock to ensure high accuracy machining.

FJV 5 Face-35/60 shown

Ergonomics

Design focus on ergonomics provides unsurpassed ease of operation

Large door opening

The telescoping front cover provides an extremely wide opening for the convenient loading and unloading of large workpieces.

Table height : **870 mm** (FJV 5 Face-35, FJV 5 Face-60)

Designed for convenient setup of fixtures and loading / unloading of workpieces (FJV 5 Face-100 : 970 mm).

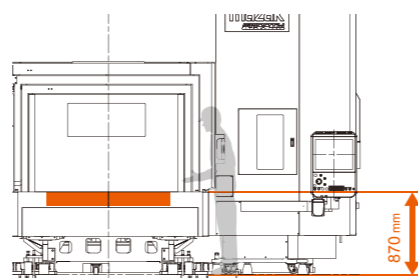

Shown with optional equipment

End cover window*

Windows on end cover allows operator to easily monitor machining.

*Option for FJV 5 Face-35 series

Large window

Large window on the operator door allow workpiece machining to be easily monitored by the operator.



ergonomics

Adjustable CNC operation panel

The operation touch panel can be tilted to the optimum position for any operator's height to ensure ease of operation.

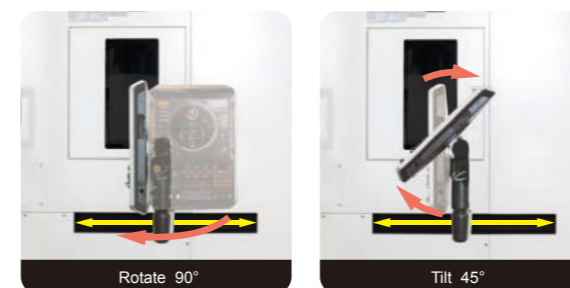

Tool magazine operation panel

The tool magazine operation panel is designed for increased ease of operation. Instead of having just a forward / reverse button for indexing the tool magazine and manually positioning the desired tool pocket, the pocket number or tool number can be input into the operation panel numeric keyboard and the desired pocket will be automatically brought into position. This is standard equipment for the different capacity tool magazines.



Remote manual pulse generator

The remote manual pulse generator provides convenient operation when the operator is not close to the CNC operation panel. Its display shows the position display and the machine coordinate values. 4 different positions can be registered in memory by the remote manual pulse generator. A wireless version is optionally available.



Machine Interference Prevention SAFETY SHIELD

When an operator manually moves the machine axes for setup, tool measurement or changing inserts, the CNC shows a synchronized 3D model on the display for checking machine interference. If any machine interference occurs, the machine motion automatically stops.

Verbal Message System VOICE ADVISER

Verbal support for machine setup and safe conditions confirmation.

Ease of Maintenance

Simplified daily checking for convenient maintenance to minimize machine down-time

1 Central maintenance area

Items requiring frequent access for machine maintenance are conveniently located on a single panel.



2 Large capacity spiral conveyors

Large 120 mm diameter spiral conveyors on both sides of the machine table are standard equipment to smoothly remove machined chips. In case higher machined chip removal capacity is required, hinge type chip conveyors on both sides of the machine table are optionally available. The standard chip conveyor on the FJV 5 Face-100 is hinge type.



3 Automatic Z-axis retraction

The Z-axis retraction automatically pulls up the spindle from the machining surface to prevent workpiece damage in the case of sudden electrical power blackout.



4 Maintenance screen

A graphical display shows the status of changing and refilling time such as for coolant, lubrication oil and filters. Ensures machine operation by providing a convenient maintenance schedule.

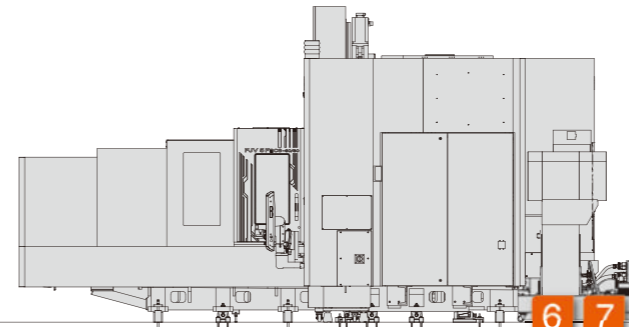
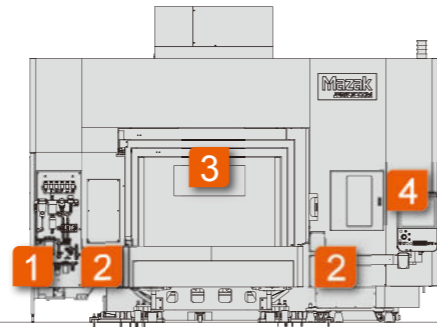
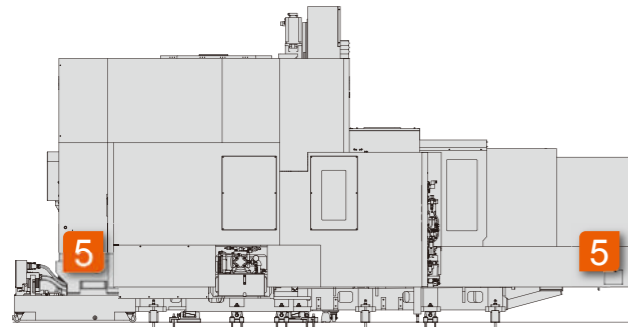

7 Cyclone coolant filter OPTION

The cyclone filter in the coolant through spindle system removes 90% of particles larger than 20µm from the coolant. As a result, the time required for cleaning the filters in the coolant system is significantly reduced.

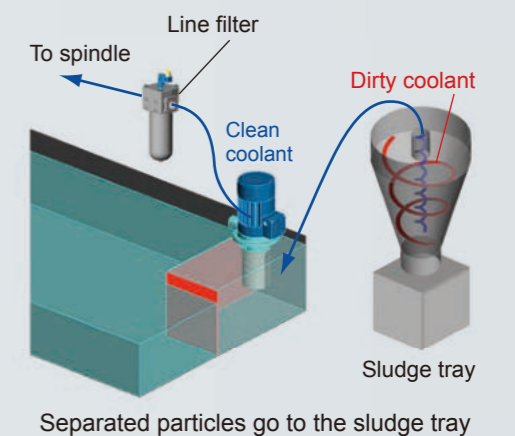

5 Designed for the smooth flow of machined chips

The inner walls of the machine coolant cover are angled more than 45 degrees to prevent the accumulation of machined chips, so that the time required for cleaning the machining area is considerably reduced.

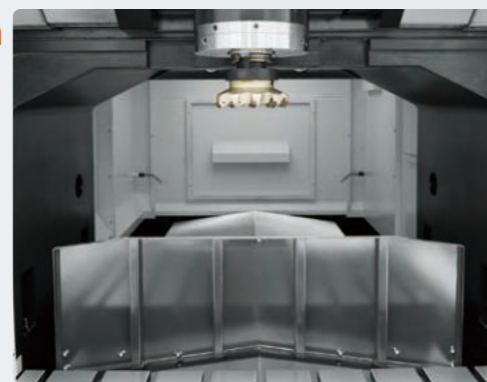

Inner wall cover



Enlarged chip ducts for smooth chip disposal

6 Coolant level gauge and filter designed for convenient checking

A white float type level gauge is used to indicate the level of coolant in the coolant tank. Additionally, the coolant hoses are easily removed for maintenance thanks to quick connect / disconnect couplings.

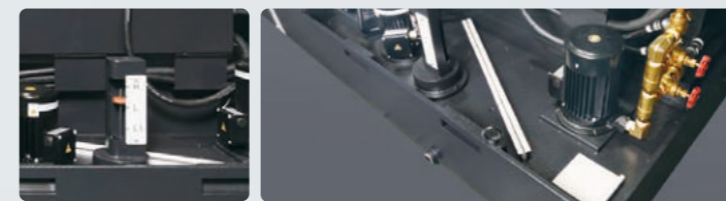

Higher Accuracy

Convenient Parameter Setting and Fine Tuning Function SMOOTH MACHINING CONFIGURATION

Machining time, finished surface smoothness and machining shape can be adjusted for improved productivity.

Variable Acceleration Control Function
VARIABLE ACCELERATION CONTROL
Variable acceleration control is a new function which permits the faster acceleration capability of linear axes to be used whenever possible. The slower acceleration of the rotary axes is not used for all program commands, resulting in faster machining cycle times.

Minimized Vibration
ACTIVE VIBRATION CONTROL
Machine vibration can be reduced to perform excellent machining accuracy and high-speed machining.

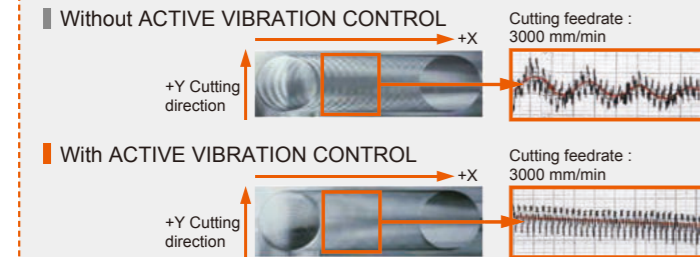

Heat Displacement Control THERMAL SHIELD

The THERMAL SHIELD is an automatic compensation for room temperature changes, which realizes enhanced continuous machining accuracy. MAZAK has performed extensive testing in a variety of environments in a temperature controlled room and has used the results to develop a control system that automatically compensates for temperature changes in the machining area. Changes in the room temperature and compensation data are shown visually.

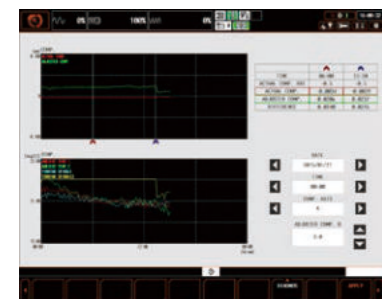

Temperature and compensation are displayed on MAZATROL SmoothG screen. Operator can adjust compensation by looking at the data.

Seamless Corner Control
SMOOTH CORNER CONTROL
Improved finished surfaces and reduced cycle times by optimized acceleration / deceleration when machining corners.

Other systems

Move to next command position after reaching current command position

SMOOTH CORNER CONTROL

Move to next command position within tolerance band



Ease of Maintenance

Comprehensive Spindle Monitoring PERFORMANCE SPINDLE

The PERFORMANCE SPINDLE monitors a variety of properties such as temperature with sensors housed in the spindle and provides useful information to the operator. Thanks to this monitoring, production loss due to machine down time can be minimized.



▲ Condition check
Temperature as well as the motor load can be displayed.



▲ Running recorder
Operation status of milling spindle (rpm / motor load) can be recorded for up to one year.

Comprehensive Maintenance Monitor MAINTENANCE SUPPORT

Useful information for improved preventative maintenance to prevent unexpected machine downtime.



MAZATROL CNC System

MAZATROL SMOOTHG

4-axes simultaneous CNC



Fastest CNC in the world

- Latest hardware and software for unprecedented speed and precision

Smooth graphical user interface

PC with Windows® 8 embedded OS
MAZATROL Smooth graphical user interface for unsurpassed ease of operation
Touch screen operation - operates similar to your smart phone / tablet

Ease of operation

Designed for unsurpassed ease of operation with advanced Intelligent Functions
Windows is a registered trademark of Microsoft Corporation in the United States and other countries.

Process home screens

Five different home process screens - each home screen displays the appropriate data in an easy-to-understand manner. Icons can be touched in each process display for additional screen displays.

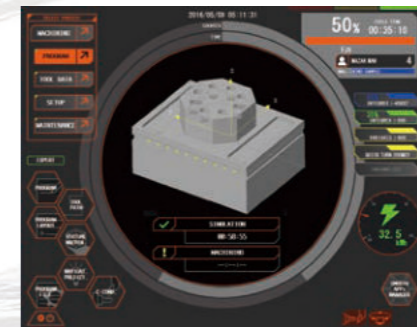

Programming



Tool data

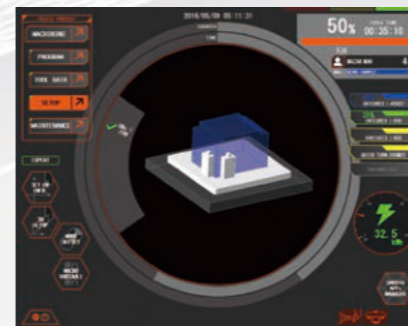

Setup

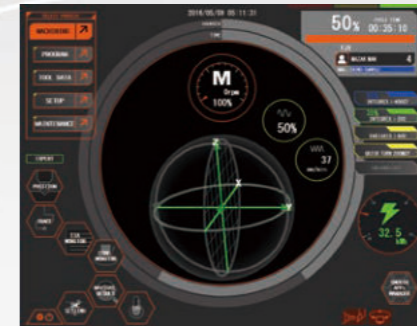

Machining



Maintenance

Programming screen links tool path, workpiece shape and programming to reduce programming time

QUICK MAZATROL

MAZATROL program, unit list and 3D workpiece shape are linked to each other. After defining a machining unit in a MAZATROL program, the 3D shape is immediately displayed to easily and quickly check for any programming error.

Quickly move to the corresponding section in the MAZATROL program by touching a feature in the 3D model

3D model in the process list is displayed with updated programming in real time

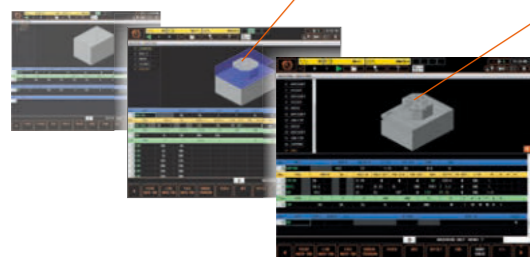

3D ASSIST

Workpiece and coordinates data can be imported from 3D CAD data to a MAZATROL program. No coordinate value inputs are required. Can reduce input errors and time for program checking.

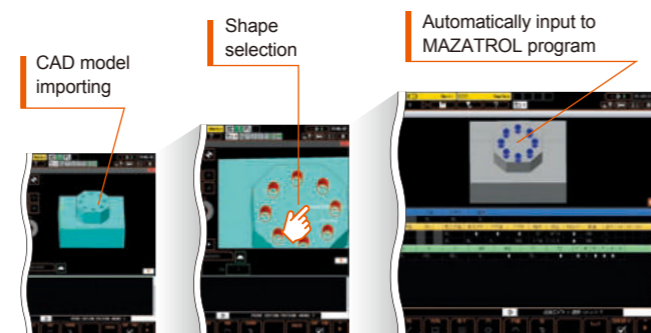

QUICK EIA

Program, process list and 3D tool path display are linked to each other. Visible search on touch screen can reduce the time for program checking.

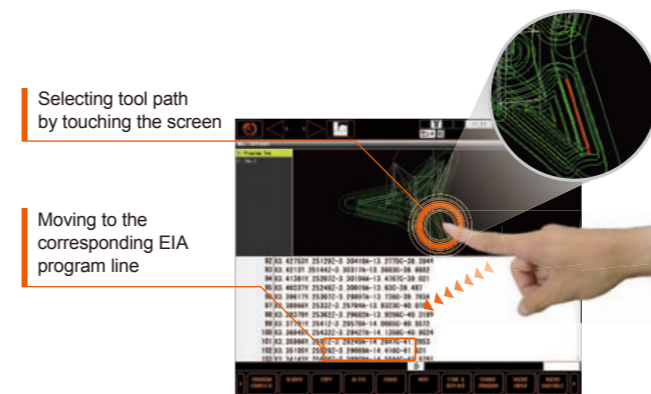

VIEW SURF

By analyzing tool path, any predictable failure on the finished surface can be visualized. Program modification can be done before machining to minimize the time for test cutting.

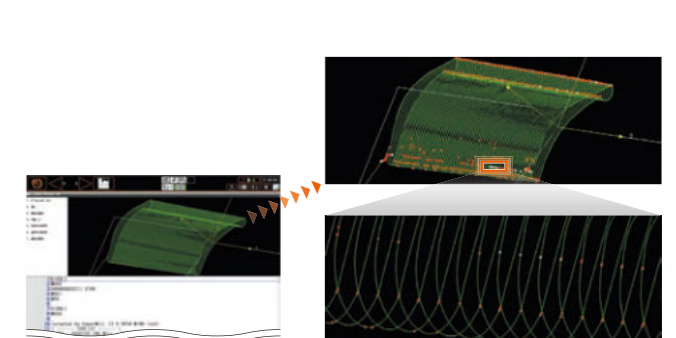

Network Integration

Convenient connection to automation equipment

Smooth Process Support Software for efficient factory management OPTION



Data sharing between SmoothG CNC and office PCs for improved production efficiency.



Networking to peripheral equipment OPTION

Convenient network connection to peripheral equipment thanks to industrial network standards.

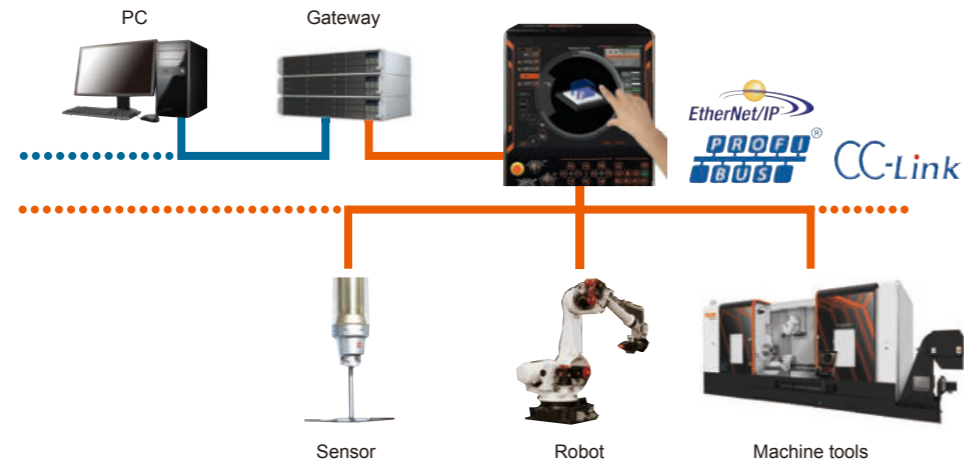

MTConnect is a registered trademark of AMT (Association for Manufacturing Technology).
EtherNet/IP is a trademark of ODVA (Open Device Net Vendor Association).
PROFIBUS is a trademark of PROFIBUS User Organization.

Table Dimensions

Unit : mm

FJV 5 Face-35/60, FJV 5 Face-35/80, FJV 5 Face-35/120

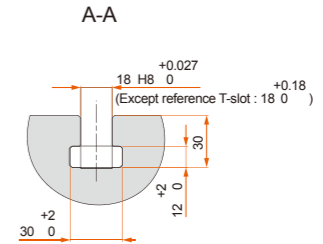
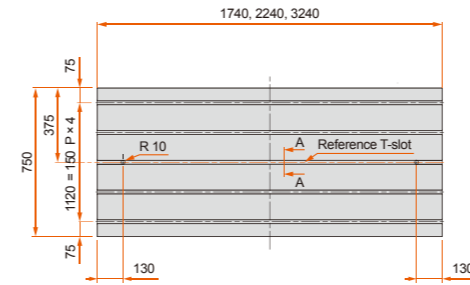

FJV 5 Face-60/80

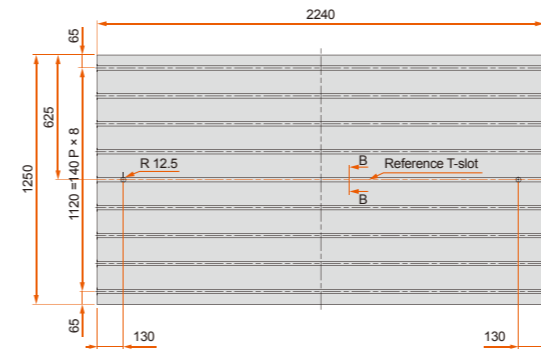

FJV 5 Face-60/120, FJV 5 Face-60/160

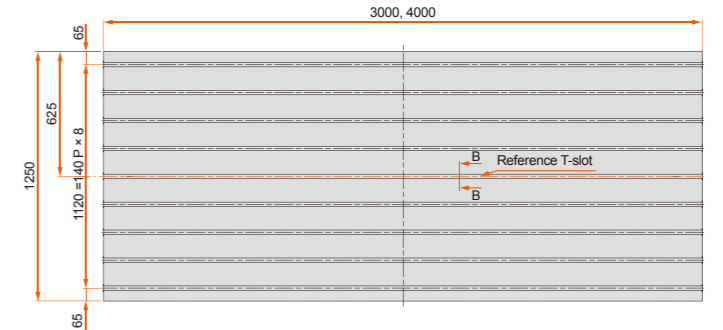

FJV 5 Face-100/120, FJV 5 Face-100/160

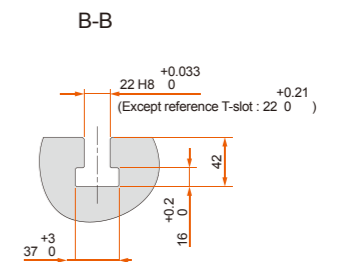
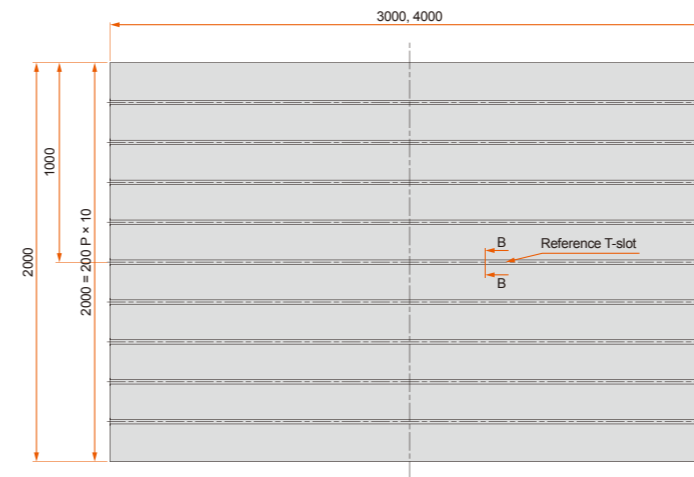

Machine Dimensions

Unit : mm

FJV 5 Face-35 series

| A | | |
|------------------|------------------|-------------------|
| FJV 5 Face-35/60 | FJV 5 Face-35/80 | FJV 5 Face-35/120 |
| 5742 mm | 6863 mm | 9315 mm |

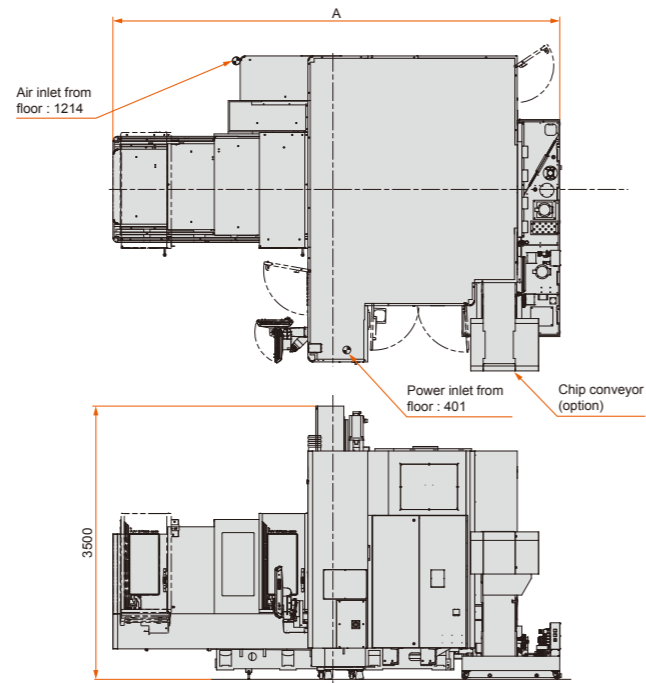
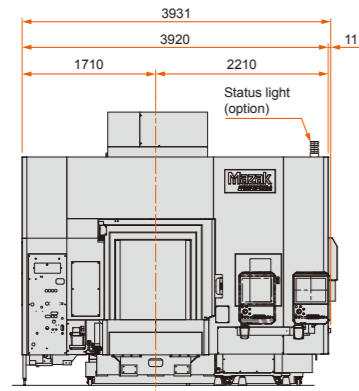

FJV 5 Face-60 series

| A | | |
|------------------|-------------------|-------------------|
| FJV 5 Face-60/80 | FJV 5 Face-60/120 | FJV 5 Face-60/160 |
| 6895 mm | 9030 mm | 11451 mm |

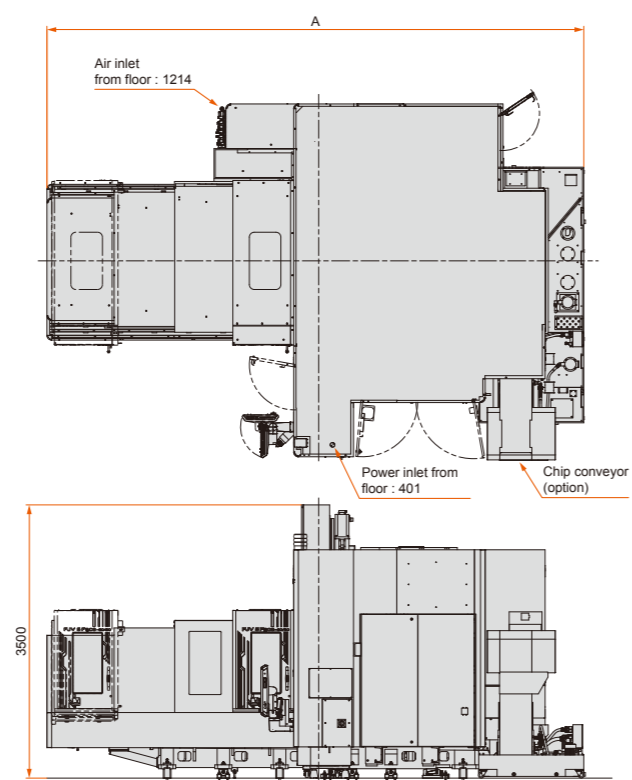
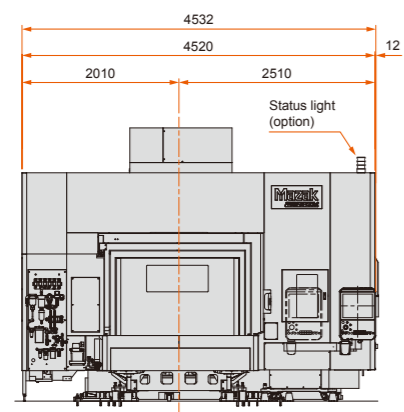

FJV 5 Face-100 series

| A | |
|--------------------|--------------------|
| FJV 5 Face-100/120 | FJV 5 Face-100/160 |
| 9372 mm | 12044 mm |

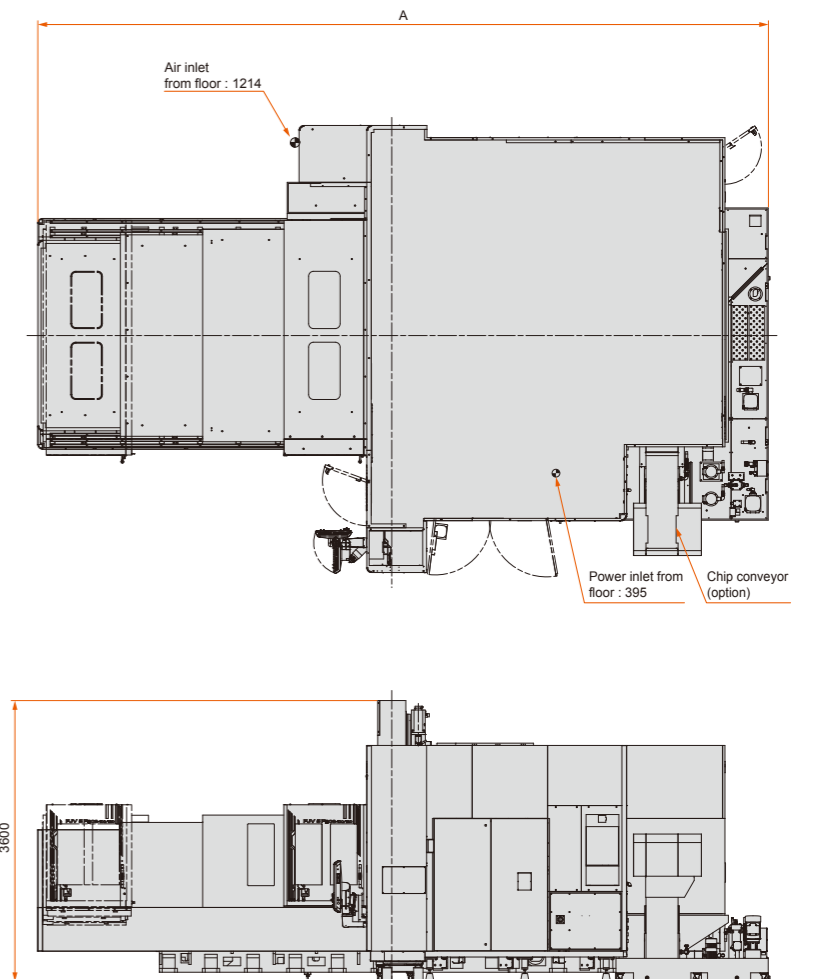
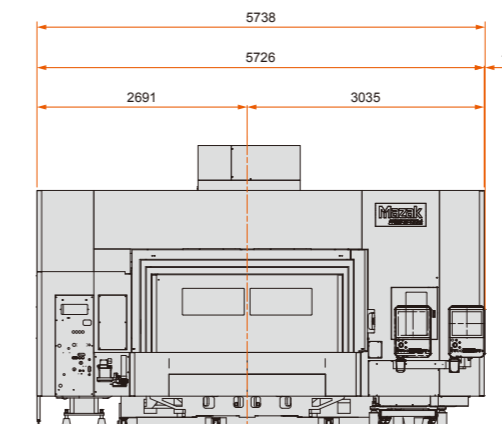

Standard Machine Specifications

| | | FJV 5 Face-35/60 | FJV 5 Face-35/80 | FJV 5 Face-35/120 | FJV 5 Face-60/80 | FJV 5 Face-60/120 | FJV 5 Face-60/160 | FJV 5 Face-100/120 | FJV 5 Face-100/160 |
|--|---|---------------------------------|-----------------------|-------------------|----------------------------------|-----------------------|--------------------|---------------------------------|-----------------------|
| Travel | X-axis (table left / right) | 1500 mm | 2000 mm | 3000 mm | 2000 mm | 3200 mm | 4200 mm | 3200 mm | 4200 mm |
| | Y-axis (spindle head back / forth) | 800 mm | | | 1400 mm | | | 2450 mm | |
| | Z-axis (spindle head up / down) | 660 mm | | | 660 mm | | | 660 mm | |
| Table | Distance from table top to spindle nose | 160 ~ 820 mm | | | 160 ~ 820 mm | | | 160 ~ 820 mm | |
| | Effective width between columns | 860 mm | | | 1500 mm | | | 2500 mm | |
| | Table size | 1740 mm × 750 mm | 2240 mm × 750 mm | 3240 mm × 750 mm | 2240 mm × 1250 mm | 3000 mm × 1250 mm | 4000 mm × 1250 mm | 3000 mm × 2000 mm | 4000 mm × 2000 mm |
| | Table load capacity (evenly distributed) | 2500 kg | 3000 kg | | 4000 kg | 5000 kg | | 5000 kg | 10000 kg |
| | Table top surface | 18 mm T-slot × 5, 150 mm pitch | | | 22 mm T-slot × 9, 140 mm pitch | | | 22 mm T-slot × 9, 200 mm pitch | |
| Spindle | Spindle speed | 35 ~ 10000 rpm | | | 35 ~ 10000 rpm | | | 35 ~ 10000 rpm | |
| | Gear ranges | 2-step (electric) | | | 2-step (electric) | | | 2-step (electric) | |
| | Spindle taper | No. 50 | | | No. 50 | | | No. 50 | |
| | Spindle bearing ID | Ø100 mm | | | Ø100 mm | | | Ø100 mm | |
| | Spindle acceleration to top speed | 3.0 sec (0 → 10000 rpm) | | | 3.0 sec (0 → 10000 rpm) | | | 3.0 sec (0 → 10000 rpm) | |
| Feedrate | Rapid traverse rate (X-axis) | 40000 mm/min | 32000 mm/min | | 40000 mm/min | 32000 mm/min | 22000 mm/min | 30000 mm/min | |
| | Rapid traverse rate (Y / Z-axis) | 40000 mm/min / 30000 mm/min | | | 40000 mm/min / 30000 mm/min | | | 40000 mm/min / 30000 mm/min | |
| | Cutting feedrate (Z-, Y-, Z-axis) | 1 ~ 30000 mm/min | 1 ~ 20000 mm/min | | 1 ~ 30000 mm/min | 1 ~ 19000 mm/min | 1 ~ 11000 mm/min | 1 ~ 19000 mm/min | |
| Automatic tool changer | Tool shank | No. 50 | | | No. 50 | | | No. 50 | |
| | Tool storage capacity | 30 | | | 30 | | | 60 | |
| | Max. tool diameter / length from (gauge line) / weight | Ø125 mm / 380 mm / 20 kg | | | Ø125 mm / 380 mm / 20 kg | | | Ø125 mm / 380 mm / 20 kg | |
| | Max. tool diameter with adjacent pockets empty | Ø210 mm | | | Ø210 mm | | | Ø210 mm | |
| | Tool selection method | Random selection, shortest path | | | Random selection, shortest path | | | Random selection, shortest path | |
| | Tool change time (chip-to-chip) | 5.0 sec | | | 6.2 sec | | | 8.5 sec | |
| Automatic tool changer for 5 Face Angle Tool | Tool shank | HSK-A63 | | | HSK-A63 | | | HSK-A63 | |
| | Tool storage capacity | 8 | | | 8 | | | 8 | |
| | Max. tool diameter / length (from gauge line) / weight | Ø125 mm / 207 mm* / 8 kg | | | Ø125 mm / 207 mm* / 8 kg | | | Ø125 mm / 207 mm* / 8 kg | |
| | Tool selection method | Random selection, shortest path | | | Random selection, shortest path | | | Random selection, shortest path | |
| | Tool change time | 32 sec | | | 32 sec | | | 32 sec | |
| | 5 Face Angle Head | 1 | | | 1 | | | 1 | |
| Motors | Spindle motor (30 min. rating [40 % ED] / cont. rating) | AC37 kW (50 HP) / 30 kW (40 HP) | | | AC 37 kW (50 HP) / 30 kW (40 HP) | | | AC37 kW (50 HP) / 30 kW (40 HP) | |
| | Flood coolant pump motor (50 / 60 Hz) | 730 W / 1210 W | | | 730 W / 1210 W | | | 730 W / 1210 W | |
| Power requirement | Required power capacity (30 min. / cont. rating) | 75.59 kVA / 65.84 kVA | 76.29 kVA / 66.54 kVA | | 75.65 kVA / 65.90 kVA | 76.21 kVA / 66.46 kVA | | 79.72 kVA / 69.80 kVA | 73.73 kVA / 63.99 kVA |
| | Air supply | More than 0.5 MPa / 1200 NL/min | | | More than 0.5 MPa / 1200 NL/min | | | More than 0.5 MPa / 1200 NL/min | |
| Machine size | Height (from floor) | 3500 mm | | | 3500 mm | | | 3600 mm | |
| | Floor space requirement | 3931 mm × 5742 mm | 3931 mm × 6863 mm | 3931 mm × 9315 mm | 4532 mm × 6895 mm | 4532 mm × 9030 mm | 4532 mm × 11451 mm | 5738 mm × 9372 mm | 5738 mm × 12044 mm |
| | Machine weight | 18700 kg | 20200 kg | 24200 kg | 27100 kg | 32100 kg | 36100 kg | 45700 kg | 47000 kg |
| Sound | Equivalent continuous sound pressure level at operator position (depend on equipment options) | Less than 80 dB (A) | | | Less than 80 dB (A) | | | Less than 80 dB (A) | |

*Depends on the tool diameter

Standard and Optional Equipment

● : Standard ○ : Option — : N/A

| Machine model | | 35/60 | 35/80 | 35/120 | 60/80 | 60/120 | 60/160 | 100/120 | 100/160 |
|-------------------------------|---|-------|-------|--------|-------|--------|--------|---------|---------|
| Spindle speed | 10000 rpm | ● | ● | ● | ● | ● | ● | ● | ● |
| | 7000 rpm | ○ | ○ | ○ | ○ | ○ | ○ | ○ | ○ |
| Tool shank | CAT No.50 | ● | ● | ● | ● | ● | ● | ● | ● |
| Multi-surface Angle Tool | Multi-surface attachment | ● | ● | ● | ● | ● | ● | ● | ● |
| | MAZAK 5 Face Angle Head (2000 rpm) | ● | ● | ● | ● | ● | ● | ● | ● |
| | Standard type Angle Tool Holder | ○ | ○ | ○ | ○ | ○ | ○ | ○ | ○ |
| | Angle tool holder for side face | ○ | ○ | ○ | ○ | ○ | ○ | ○ | ○ |
| Tool magazine | 30 tool chain type magazine | ● | ● | ● | ● | ● | ● | — | — |
| | 60 tool chain type magazine | ○ | ○ | ○ | ○ | ○ | ○ | ● | ● |
| | 8 tool drum type magazine for MAZAK 5 Face Angle Tool Holder (HSK-63) | ● | ● | ● | ● | ● | ● | ● | ● |
| Pallet changer | 2 pallet changer | ○ | ○ | — | ○ | ○ | ○ | — | — |
| Additional axis preparation | Additional axis preparation | ○ | ○ | ○ | ○ | ○ | ○ | ○ | ○ |
| | Additional axis preparation for 2 pallet changer | ○ | ○ | — | ○ | ○ | ○ | — | — |
| Pneumatic / hydraulic fixture | Pneumatic fixture preparation for 2 port | ○ | ○ | ○ | ○ | ○ | ○ | ○ | ○ |
| | Pneumatic fixture preparation for 4 port | ○ | ○ | ○ | ○ | ○ | ○ | ○ | ○ |
| | Hydraulic fixture preparation for 2 port | ○ | ○ | ○ | ○ | ○ | ○ | ○ | ○ |
| | Hydraulic fixture preparation for 4 port | ○ | ○ | ○ | ○ | ○ | ○ | ○ | ○ |
| | Pneumatic fixture preparation for 2PC / 2 port (pallet × 1) | ○ | ○ | — | ○ | ○ | ○ | — | — |
| | Pneumatic fixture preparation for 2PC / 2 port (pallet × 2) | ○ | ○ | — | ○ | ○ | ○ | — | — |
| | Hydraulic fixture preparation for 2PC / 2 port (pallet × 1) | ○ | ○ | — | ○ | ○ | ○ | — | — |
| | Hydraulic fixture preparation for 2PC / 2 port (pallet × 2) | ○ | ○ | — | ○ | ○ | ○ | — | — |
| | 1 port for seating confirmation | ○ | ○ | — | ○ | ○ | ○ | — | — |
| Coolant system | Flood coolant | ● | ● | ● | ● | ● | ● | ● | ● |
| | Coolant for Multi-Face machining attachment | ○ | ○ | ○ | ○ | ○ | ○ | ○ | ○ |
| | Preparation for chip conveyor (right side discharge) | ● | ● | ● | ● | ● | ● | ● | ● |
| | Large coolant tank (900 L) | ○ | ○ | ○ | — | — | — | — | — |
| | Large coolant tank (1000 L) | — | — | — | ○ | ○ | ○ | — | — |
| | Chip pan specification | ○ | ○ | ○ | ○ | ○ | ○ | ○ | ○ |
| | Niagara coolant** | ○ | ○ | ○ | ○ | ○ | ○ | ○ | ○ |
| | Cover coolant** | ○ | ○ | ○ | ○ | ○ | ○ | ● | ● |
| | Coolant through spindle (0.5MPa) with cyclone filter | ○ | ○ | ○ | ○ | ○ | ○ | ○ | ○ |
| | High pressure coolant through spindle (1.5 MPa) with cyclone filter | ○ | ○ | ○ | ○ | ○ | ○ | ○ | ○ |
| | High pressure coolant through spindle (7.0 MPa) | ○ | ○ | ○ | ○ | ○ | ○ | ○ | ○ |
| | SUPERFLOW coolant system | ○ | ○ | ○ | ○ | ○ | ○ | ○ | ○ |
| | Pressure switch for coolant through spindle | ○ | ○ | ○ | ○ | ○ | ○ | ○ | ○ |
| Hand held coolant nozzle | ○ | ○ | ○ | ○ | ○ | ○ | ○ | ○ | |

** With coolant for Multi-Face machining attachment, nozzle will be equipped below column.
 ** Large coolant tank required for all machines except FJV 5 Face-100
 The above specifications are for European market.
 Standard and optional specifications vary by market.

● : Standard ○ : Option — : N/A

| Machine model | | 35/60 | 35/80 | 35/120 | 60/80 | 60/120 | 60/160 | 100/120 | 100/160 |
|------------------------|--|-------|-------|--------|-------|--------|--------|---------|---------|
| Coolant system | Work air blast | ● | ● | ● | ● | ● | ● | ● | ● |
| | Air through spindle (available during spindle rotation)** | ● | ● | ● | ● | ● | ● | ● | ● |
| | Oil skimmer | ○ | ○ | ○ | ○ | ○ | ○ | ○ | ○ |
| | Mist collector (fully enclosed cover required) | ○ | ○ | ○ | ○ | ○ | ○ | ○ | ○ |
| | Coolant level float gauge | ● | ● | ● | ● | ● | ● | ● | ● |
| Internal chip conveyor | Spiral chip conveyor (Inverter) | ● | ● | ● | ● | ● | ● | — | — |
| | Internal chip conveyor (hinge) | ○ | ○ | ○ | ○ | ○ | ○ | ● | ● |
| | Inverter system for hinge type chip conveyor | ○ | ○ | ○ | ○ | ○ | ○ | ○ | ○ |
| Chip conveyor | CONSEP chip conveyor (right side discharge) | ○ | ○ | ○ | ○ | ○ | ○ | ○ | ○ |
| | Hinge type chip conveyor (abrasion resistant / right side discharge) | ○ | ○ | ○ | ○ | ○ | ○ | ○ | ○ |
| | Inverter system for chip conveyor | ○ | ○ | ○ | ○ | ○ | ○ | ○ | ○ |
| | Chip bucket (rotary type) | ○ | ○ | ○ | ○ | ○ | ○ | ○ | ○ |
| | Chip bucket (fixed type) | ○ | ○ | ○ | ○ | ○ | ○ | ○ | ○ |
| Measuring system | Mazak monitoring system B (optical) OMP60 | ○ | ○ | ○ | ○ | ○ | ○ | ○ | ○ |
| | Preparation for Mazak monitoring system B (optical) OMP60 | ○ | ○ | ○ | ○ | ○ | ○ | ○ | ○ |
| | Work measuring print out function (without printer) | ○ | ○ | ○ | ○ | ○ | ○ | ○ | ○ |
| | Automatic tool length measurement & tool breakage detection | ○ | ○ | ○ | ○ | ○ | ○ | ○ | ○ |
| | Laser tool measurement (max. tool diameter ø210 mm) | ○ | ○ | ○ | ○ | ○ | ○ | ○ | ○ |
| Accuracy | Ball-screw core cooling (X / Y / Z-axes) | ● | ● | ● | ● | ● | ● | ● | ● |
| | Chiller unit for spindle | ● | ● | ● | ● | ● | ● | ● | ● |
| | Scale feedback system (X / Y-axes) | ○ | ○ | ○ | ○ | ○ | ○ | ○ | ○ |
| | Scale feedback system (X / Y / Z-axes) | ○ | ○ | ○ | ○ | ○ | ○ | ○ | ○ |
| | Coolant temperature control | ○ | ○ | ○ | ○ | ○ | ○ | ○ | ○ |
| Setup / Automation | Absolute position detection | ● | ● | ● | ● | ● | ● | ● | ● |
| | Manual pulse generator (wired) | ○ | ○ | ○ | ● | ● | ● | ● | ● |
| | Manual pulse generator (wireless) | ○ | ○ | ○ | ○ | ○ | ○ | ○ | ○ |
| | Automatic power ON / OFF + warm-up operation | ● | ● | ● | ● | ● | ● | ● | ● |
| Others | Enclosed overall cover | ● | ● | ● | ● | ● | ● | ● | ● |
| | Fully enclosed cover | ○ | ○ | ○ | ○ | ○ | ○ | ○ | ○ |
| | End cover window | ○ | ○ | ○ | ● | ● | ● | ● | ● |
| | Operator door interlock | ● | ● | ● | ● | ● | ● | ● | ● |
| | Work light (LED) | ● | ● | ● | ● | ● | ● | ● | ● |
| | Additional work light (LED) | ○ | ○ | ○ | ○ | ○ | ○ | ○ | ○ |
| | Machining end buzzer | ○ | ○ | ○ | ○ | ○ | ○ | ○ | ○ |
| | Status light (3 colors) | ○ | ○ | ○ | ○ | ○ | ○ | ○ | ○ |
| | Status light machining end : yellow | ○ | ○ | ○ | ○ | ○ | ○ | ○ | ○ |
| | Status light alarm : red | ○ | ○ | ○ | ○ | ○ | ○ | ○ | ○ |
| | Air line water filter | ● | ● | ● | ● | ● | ● | ● | ● |

** Not available with angle head and angle tool
 The above specifications are for European market.
 Standard and optional specifications vary by market.

