

Mazak

YAMAZAKI MAZAK CORPORATION

1-131 Takeda, Oguchi-cho, Niwa-gun, Aichi-pref., Japan
TEL : +(81)587-95-1131 FAX : +(81)587-95-2717

www.mazak.com

- Specifications are subject to change without notice.
- This product is subject to all applicable export control laws and regulations.
- The accuracy data and other data presented in this catalogue were obtained under specific conditions. They may not be duplicated under different conditions. (room temperature, workpiece materials, tool material, cutting conditions, etc.)

MTV SERIES SmoothCNC 17.09.1000 T 99J284217E0

MTV SERIES



515/40

655/60

655/80

815/80

815/120

SMOOTH
TECHNOLOGY

MTV

S E R I E S

Mazak

Advanced features of the MAZATROL SmoothG CNC

Touch screen operation

— Operates similar to your smart phone / tablet

PC with Windows® 8 embedded OS

Fastest CNC in the world

— Latest hardware and software for unprecedented speed and precision

Easy conversational programming

Smooth graphical user interface and support functions for unsurpassed ease of operation

Fine tuning functions

— Easily configure machine parameters for different workpiece materials and application requirements

MTConnect® ready

— Convenient networking

Windows is a registered trademark of Microsoft Corporation in the United States and other countries.
MTConnect is a registered trademark of AMT in the United States and other countries.



MAZATROL SMOOTHG

The MAZATROL SmoothC is optionally available.

High rigidity, Heavy Duty Cutting

Excellent table accessibility for convenient operation thanks to column-feed design

Outstanding versatility with a wide machining envelope and exceptional table load capacity



MTV-815/80
(MAZATROL SmoothG)

Table load capacity

1500 kg (3309 lbs) (515/40)
2000 kg (4409 lbs) (655/60)
2500 kg (5511 lbs) (655/80)
3000 kg (6614 lbs) (815/80)
3000 kg (6614 lbs) (815/120)

Spindle

6000 rpm for 515/40, 655/60, 655/80
Output: 18.5 kW (25 HP) torque: 759 N·m (40 % ED / 30 min. rating)
Output: 15 kW (20 HP) torque: 615 N·m (cont. rating)
6000 rpm for 815/80, 815/120 (option for 515/40, 655/60, 655/80)
Output: 26 kW (35 HP) torque: 1067 N·m (40 % ED / 30 min. rating)
Output: 15 kW (20 HP) torque: 615 N·m (cont. rating)

Note: Spindle specifications vary by market.

Vertical machining center

MTV SERIES

Higher Productivity

Powerful spindle for any workpiece material

Unsurpassed spindle performance

The spindle with a top speed of 6000 rpm delivers unsurpassed performance over a wide variety of production requirements.

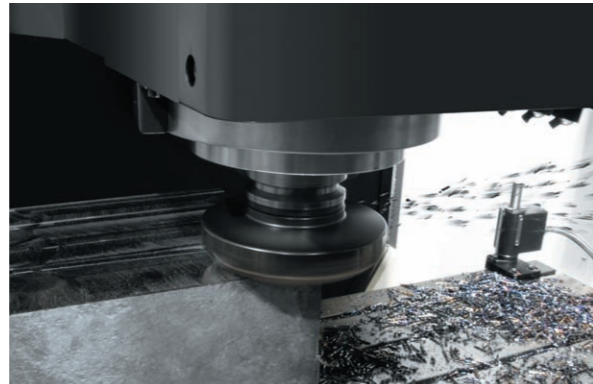

6000 rpm spindle for 815/80, 815/120 (option for 515/40, 655/60, 655/80)

6000 rpm spindle for 515/40, 655/60, 655/80

Spindle : **18.5 kW (25 HP)** (40 % ED / 30 min. rating)
 Torque : **759 N·m (560 ft·lbs)** (40 % ED / 30 min. rating)
 Drilling capacity (S45C) : $\varnothing 50$ mm ($\varnothing 1.97$ "")
 Tapping capacity (S45C) : M45×P4.5

Spindle : **26 kW (35 HP)** (40 % ED / 30 min. rating)
 Torque : **1067 N·m (787 ft·lbs)** (40 % ED / 30 min. rating)
 Drilling capacity (S45C) : $\varnothing 70$ mm ($\varnothing 2.76$ "")
 Tapping capacity (S45C) : M45×P4.5

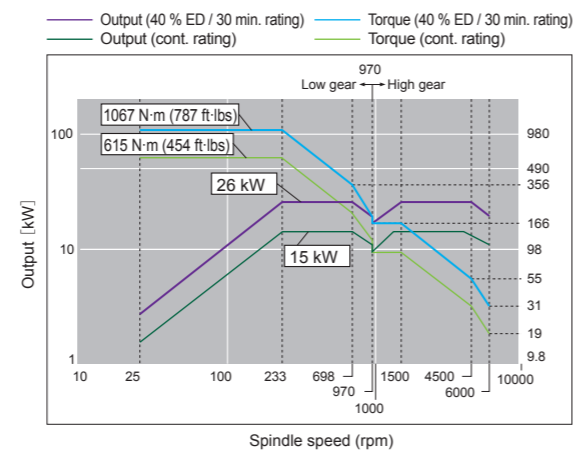
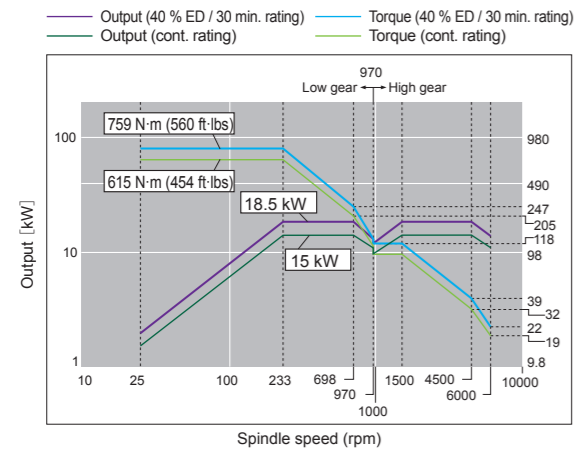

Outstanding versatility with a large machining envelope and exceptional table load capacity

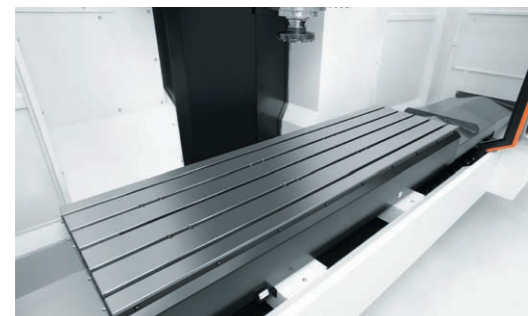
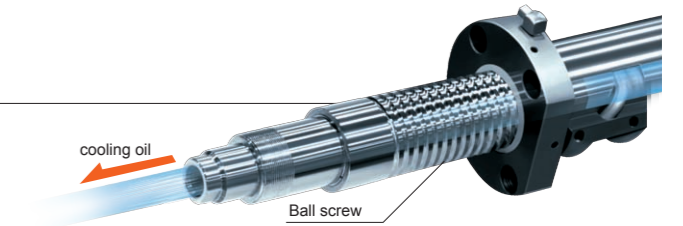

	Table size	Max. workpiece size	Max. load on table
MTV-515/40	1300 mm×550 mm (51.18"×21.65")	1300 mm×550 mm×680 mm (51.18"×21.65"×26.77")	1500 kg (3307 lbs)
MTV-655/60	1740 mm×650 mm (68.50"×25.59")	1740 mm×650 mm×770 mm (68.50"×25.59"×30.31")	2000 kg (4409 lbs)
MTV-655/80	2240 mm×650 mm (88.19"×25.59")	2240 mm×650 mm×770 mm (88.19"×25.59"×30.31")	2500 kg (5511 lbs)
MTV-815/80	2240 mm×810 mm (88.19"×31.89")	2240 mm×810 mm×870 mm (88.19"×31.89"×34.25")	3000 kg (6614 lbs)
MTV-815/120	3240 mm×810 mm (127.56"×31.89")	3240 mm×810 mm×870 mm (127.56"×31.89"×34.25")	3000 kg (6614 lbs)

Higher Accuracy

Ball screw core cooling for all axes

Temperature controlled cooling oil circulates through the ball screw cores to ensure stable machining accuracy over extended periods of high speed operation.



Designed to meet a wide variety of workpieces

High column specification OPTION

The spindle position is raised 200 mm (7.87") compared to that of the standard specification. The maximum workpiece height is 1070 mm (42.13").

Note : MTV-815 standard machine maximum workpiece height is 870 mm (34.25").

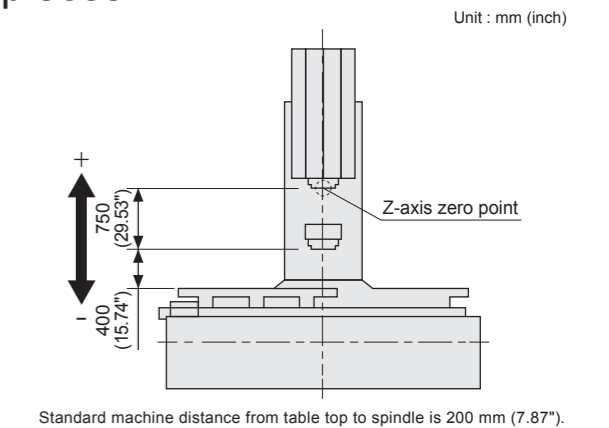

Standard machine distance from table top to spindle is 200 mm (7.87").

2 pallet changer OPTION

Idle time is minimized by setting up the next workpiece during the machining of the current workpiece for enhanced productivity

	MTV-515/40	MTV-655/60	MTV-655/80	MTV-815/80	MTV-815/120
Table size	1300 mm×550 mm (51.18"×21.65")	1740 mm×650 mm (68.50"×25.59")	2240 mm×650mm (88.19"×25.59")	2240 mm×750 mm* (88.19"×29.53")	3240 mm×750 mm* (127.56"×29.53")
Max. pallet load	1500 kg (3307 lbs)	2000 kg (4409 lbs)	2500 kg (5511 lbs)	3000 kg (6614 lbs)	3000 kg (6614 lbs)
Max. workpiece dimensions	1300 mm×550 mm×600 mm (51.18"×21.65"×23.62")	1740 mm×650 mm×690 mm (68.50"×25.59"×27.17")	2240 mm×650 mm×690 mm (88.19"×25.59"×27.17")	2240 mm×750 mm×790 mm (88.19"×29.53"×31.10")	3240 mm×750 mm×790 mm (127.56"×29.53"×31.10")
T-slot	18 mm (0.71") T-slot ×5 slots 100 mm (3.94") pitch	18 mm (0.71") T-slot ×5 slots 125 mm (4.92") pitch	18 mm (0.71") T-slot ×5 slots 125 mm (4.92") pitch	18 mm (0.71") T-slot ×5 slots 150 mm (5.91") pitch	18 mm (0.71") T-slot ×5 slots 150 mm (5.91") pitch

Intelligent Pocket Milling

The cutting width of the material on the tool is maintained to a constant depth. This reduces the variation in the cutting load allowing tools to be used to their full potential.

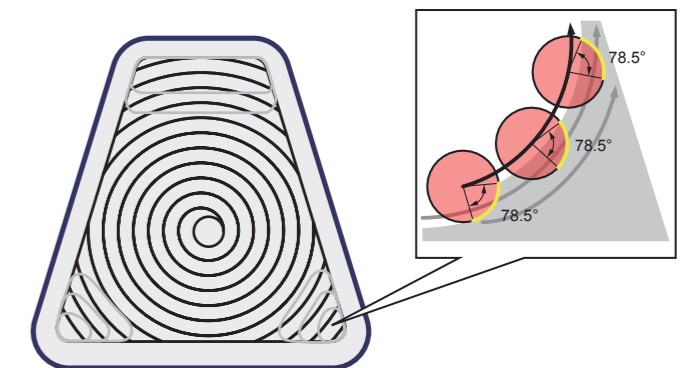

Higher Productivity

SMOOTH MACHINING CONFIGURATION

Machining time, finished surface smoothness and machining shape can be adjusted for improved productivity.



VARIABLE ACCELERATION CONTROL

Variable acceleration control is a new function which permits the faster acceleration capability of linear axes to be used whenever possible. The slower acceleration of the rotary axes is not used for all program commands, resulting in faster machining cycle times.

SMOOTH CORNER CONTROL

Improved finished surfaces and reduced cycle times by optimized acceleration / deceleration when machining corners.

Other systems

Move to next command position after reaching current command position

SMOOTH CORNER CONTROL

Move to next command position within tolerance band

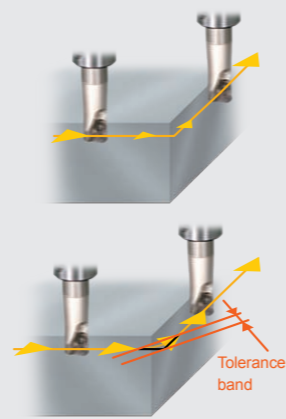

ACTIVE VIBRATION CONTROL

Machine vibration can be reduced to perform excellent machining accuracy and high-speed machining.

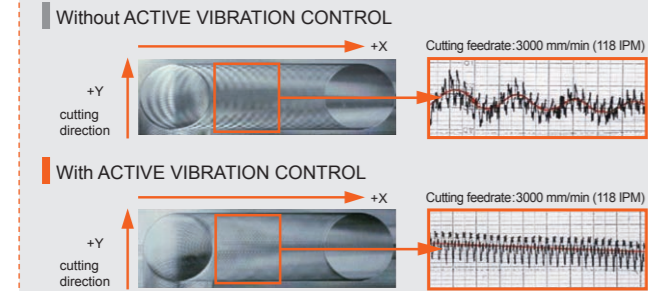

THERMAL SHIELD

THERMAL SHIELD is an automatic compensation system for room temperature changes, which realizes enhanced continuous machining accuracy. MAZAK has performed extensive testing in a variety of environments in a temperature controlled room and has used the results to develop a control system that automatically compensates for temperature changes in the machining area. Changes in the room temperature and compensation data are shown visually.



Temperature and compensation is displayed on screen. Operator can adjust compensation by looking at the data.

Ease of Maintenance

Comprehensive Spindle Monitoring - PERFORMANCE SPINDLE



PERFORMANCE SPINDLE monitors a variety of properties such as temperature with sensors housed in the spindle and provides useful information to the operator. Thanks to this monitoring, production loss due to machine down time can be minimized.



▲ Condition check
Temperature as well as the motor load can be displayed.



▲ Running recorder
Operation status of milling spindle (rpm / motor load) can be recorded for up to one year.

Comprehensive Maintenance Monitor - MAINTENANCE SUPPORT

Useful information for improved preventative maintenance to prevent unexpected machine downtime.



Detachable covers on both sides

Detachable covers on both sides provide ease of chip disposal and convenient maintenance.

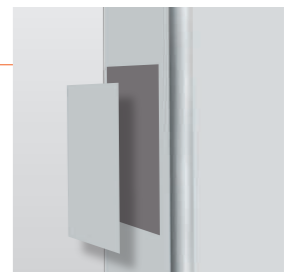

Central maintenance area

Items requiring frequent access for machine maintenance are conveniently located on a single panel.



Ergonomics

Designed for convenient operation

ergonomics



Excellent accessibility

Since the column moves for the Y-axis stroke, there is no table saddle. As a result, the distance from the front of the machine to the table is very short. This allows excellent accessibility to the table for workpiece loading / unloading and workpiece setup.



Large windows

The large front door windows allow workpiece machining to be easily monitored by the operator.

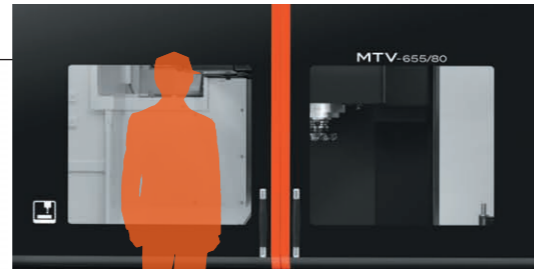

Convenient access for overhead crane

For ease of operation when loading / unloading workpieces when using overhead crane.

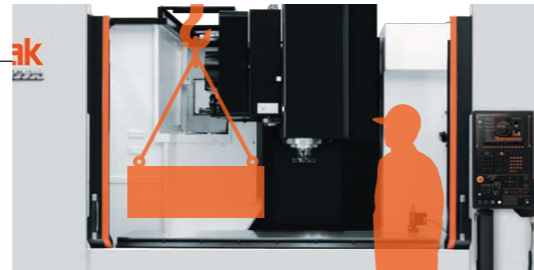

Convenient rear tool magazine access

A stepped platform with a railing is standard equipment for convenient access to the tool magazine.



CNC operation panel

MAZATROL *SMOOTHG*

Operation touch panel can be tilted to the optimum position for any operator's height to ensure ease of operation.



MAZATROL *SMOOTHC*

Operation touch panel can be rotated for ease of operation.



Machine Interference Prevention - SAFETY SHIELD

MAZATROL *SMOOTHG*

When an operator manually moves the machine axes for setup, tool measurement or changing inserts, the CNC shows a synchronized 3D model on the display for checking machine interference. If any machine interference occurs, the machine motion automatically stops. This function for use during automatic operation is optionally available.

Verbal Message System - VOICE ADVISER

MAZATROL *SMOOTHG*

Verbal support for machine setup and safe conditions confirmation.

MAZATROL CNC System

MAZATROL SMOOTHG

4 axes simultaneous CNC



Fastest CNC in the world

— Latest hardware and software for unprecedented speed and precision

Smooth graphical user interface

PC with Windows® 8 embedded OS
MAZATROL Smooth graphical user interface for unsurpassed ease of operation
Touch screen operation — operates similar to your smart phone / tablet

Ease of operation

Designed for unsurpassed ease of operation with advanced Intelligent Functions
Windows is a registered trademark of Microsoft Corporation in the United States and other countries.

Process home screens

Five different home process screens — each home screen displays the appropriate data in an easy-to-understand manner. Icons can be touched in each process display for additional screen displays.

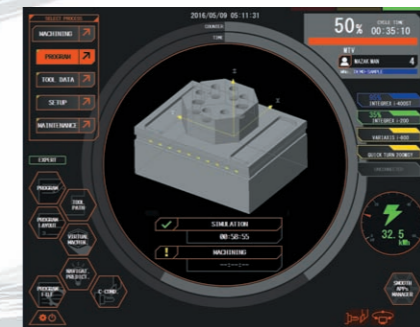

Programming

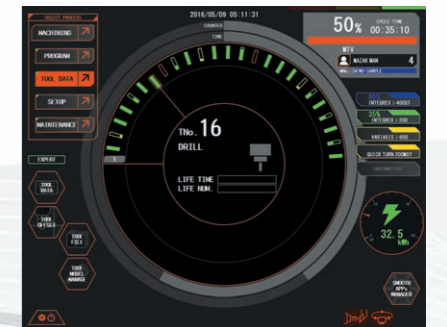

Tool data

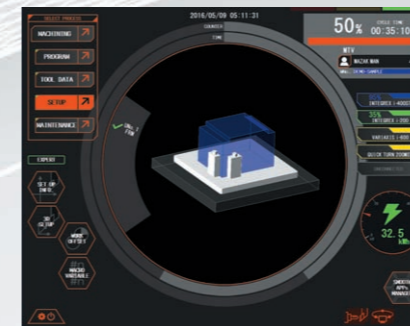

Set up

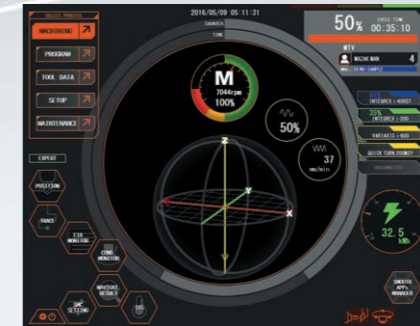

Machining



Maintenance

Programming screen links tool path, workpiece shape and programming to reduce programming time.

QUICK MAZATROL

MAZATROL program, unit list and 3D workpiece shape are linked to each other. After defining a machining unit in a MAZATROL program, the 3D shape is immediately displayed to easily and quickly check for any programming error.

3D ASSIST

Workpiece and coordinates data can be imported from 3D CAD data to a MAZATROL program. No coordinate value inputs are required. Can reduce input errors and time for program checking.

QUICK EIA

Program, process list and 3D tool path display are linked to each other. Visible search on touch screen can reduce the time for program checking.

VIEW SURF

By analyzing tool path, any predictable failure on the finished surface can be visualized. Program modification can be done before machining to minimize the time for test cutting.

Quickly move to the corresponding section in the MAZATROL program by touching a feature in the 3D model

3D model in the process list is displayed with updated programming in real time

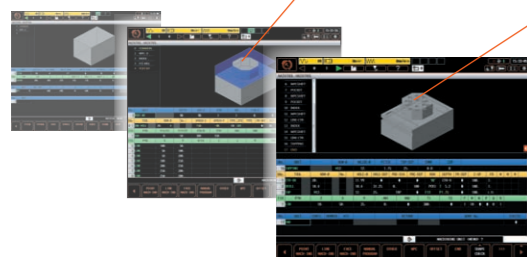

CAD model importing

Shape selection

Automatically input to MAZATROL program



Selecting tool path by touching the screen

Moving to the corresponding EIA program line

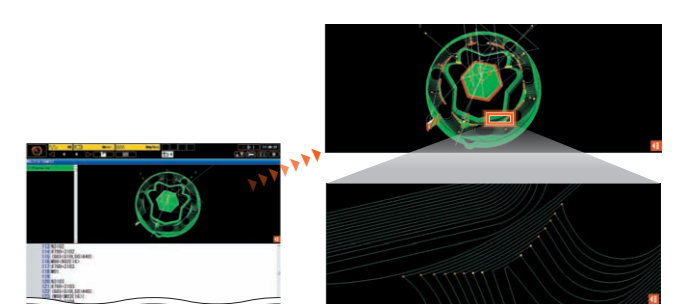
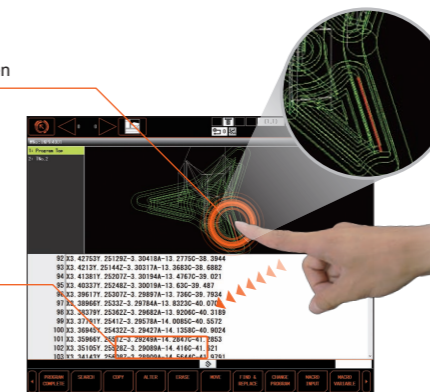

MAZATROL CNC System

MAZATROL SMOOTHC

4-axes simultaneous CNC

Fastest CNC in the world

— Latest hardware and software for unprecedented speed and precision
Same servo as MAZATROL SmoothG

Essential functions for increased ease of programming

Ease of operation



Home screen

The home screen displays overall process status in an easy to understand manner.

Comprehensive status display on one screen

Machining

Displays axes in operation and load on motors.

Programming

Displays the simulation time and machining time.

Tool data

Displays status of tool layout.

Set up

Displays status of workpiece coordinate setting.

Maintenance

Overview of the status of items requiring maintenance.

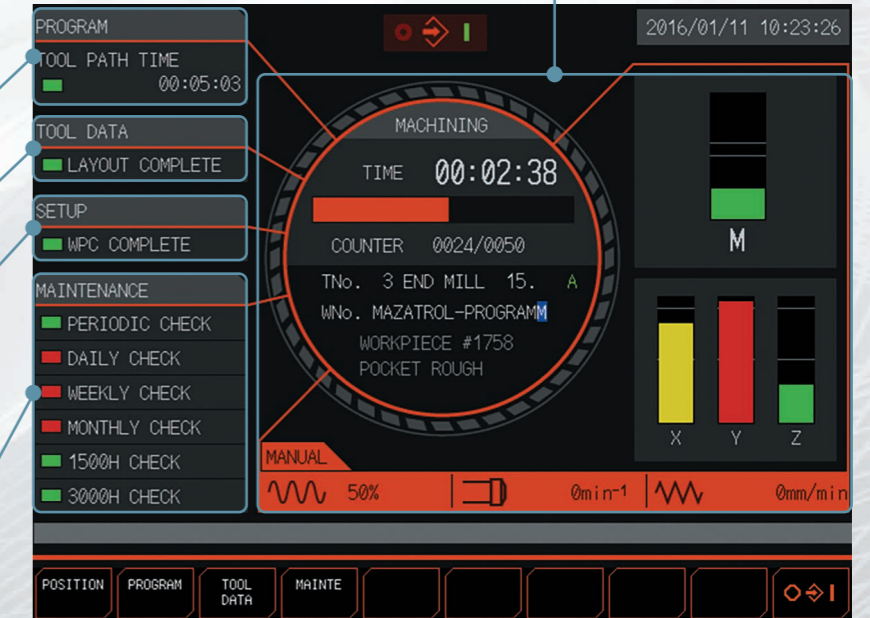

Simplified display and key input operation

Following traditional conversational MAZATROL programming, this new system is designed for ease of operation by simplified key operation.



Menu keys under the display can be pressed to go to other pages for program data input and editing.

Home screen key goes to the home screen from any display.

Compact keypad with unique design for ease of input

MAZATROL conversational programming

MAZATROL interactive programming uses conversational language and automatically determines cutting conditions, M codes, and G codes. Even a beginner operator can quickly make programs.



Machine Dimensions

Unit : mm (inch)

MTV-515/40

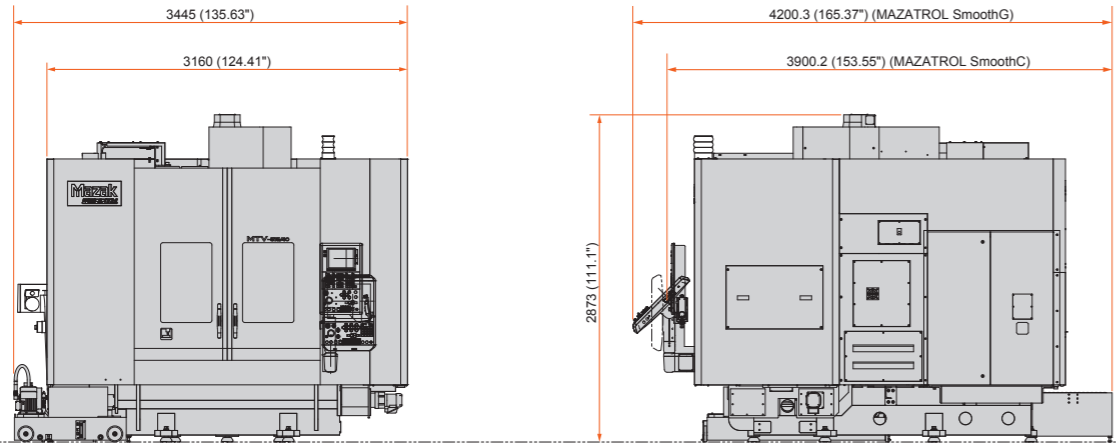

Shown with optional status light and chip conveyor

MTV-815/80

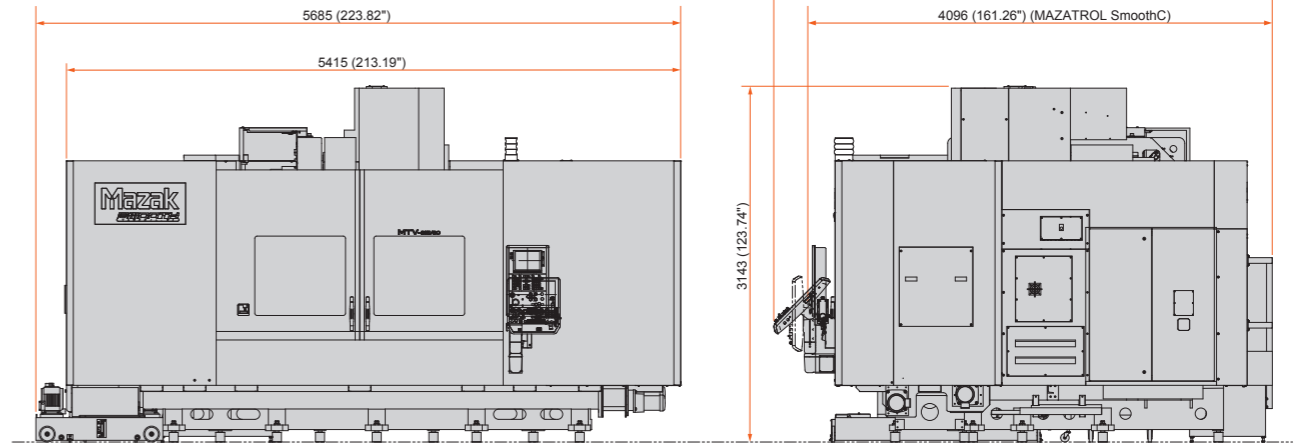

Shown with optional status light and chip conveyor

MTV-655/60

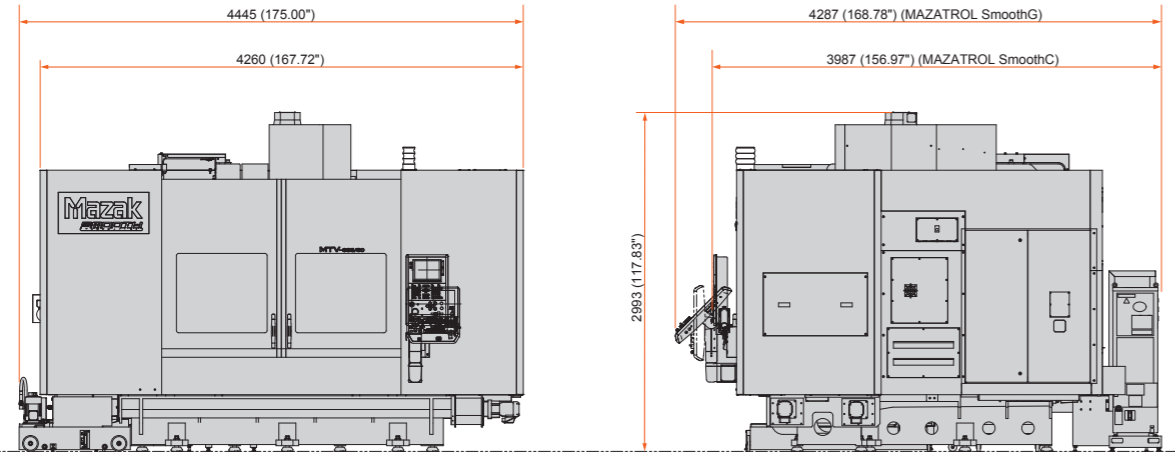

Shown with optional status light and chip conveyor

MTV-815/120

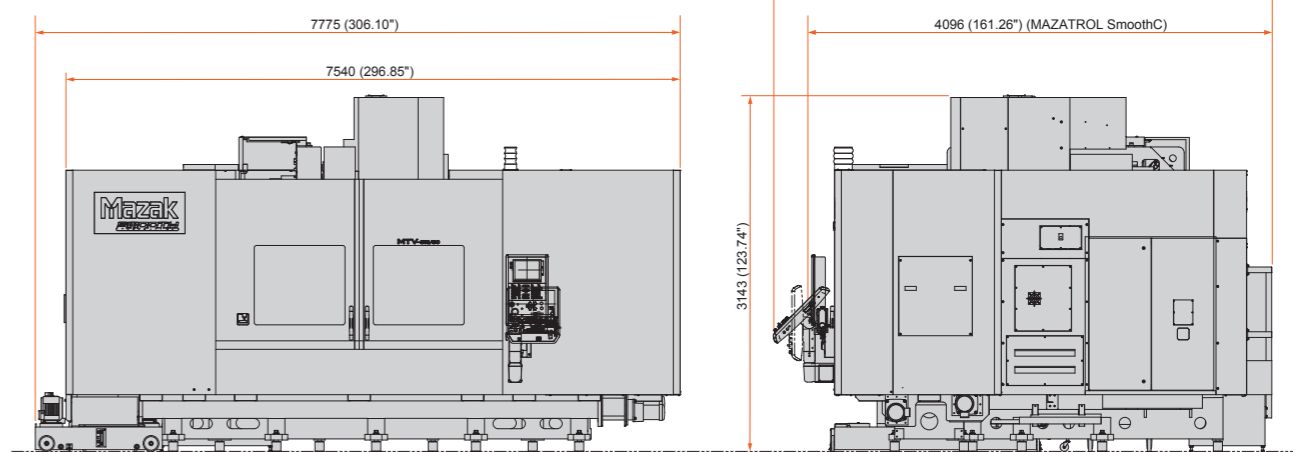

Shown with optional status light and chip conveyor

MTV-655/80

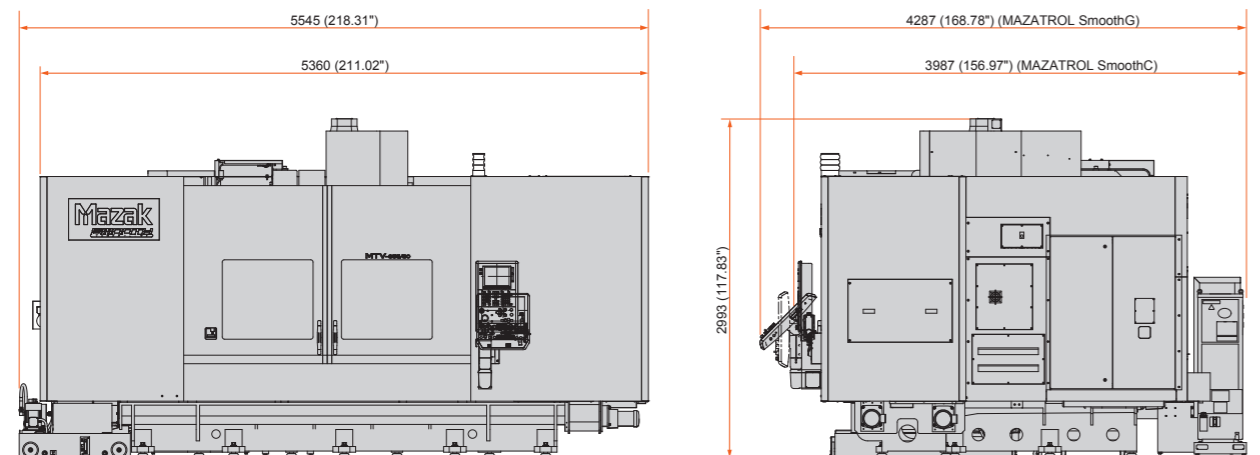

Shown with optional status light and chip conveyor

Table Dimensions

Unit : mm (inch)

MTV-515/40

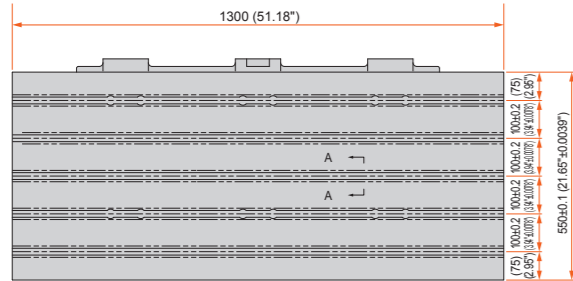

MTV-815/80

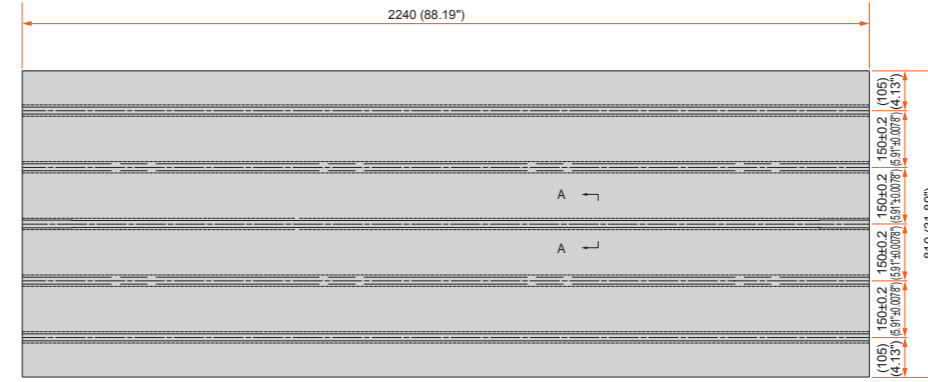

MTV-655/60

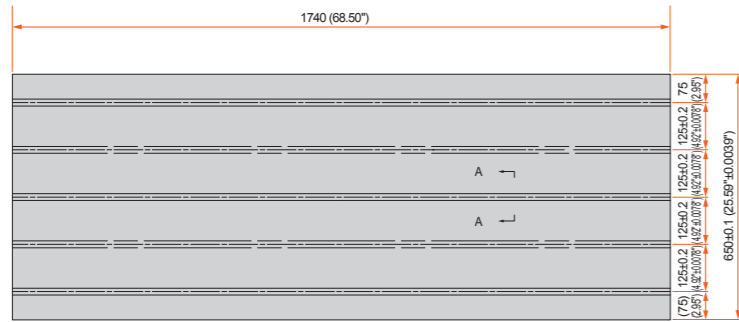

MTV-815/120

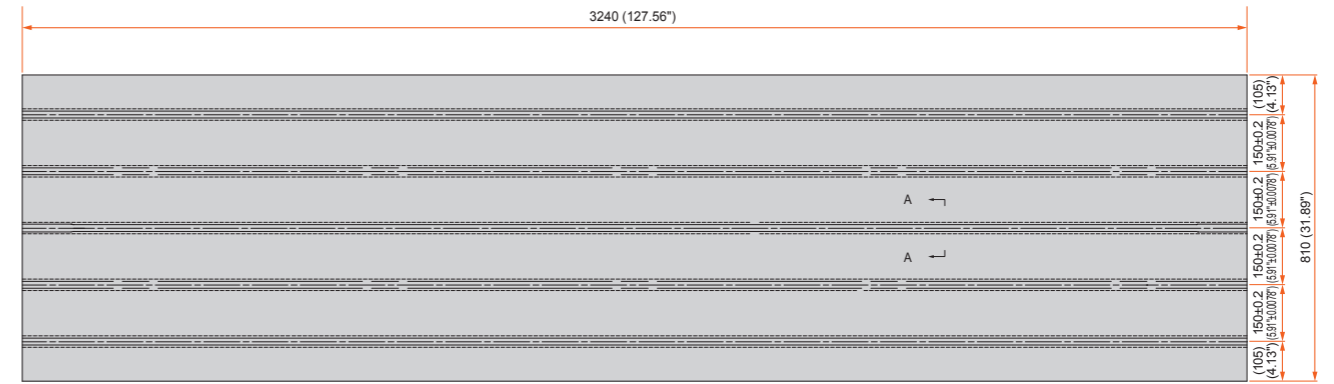

MTV-655/80

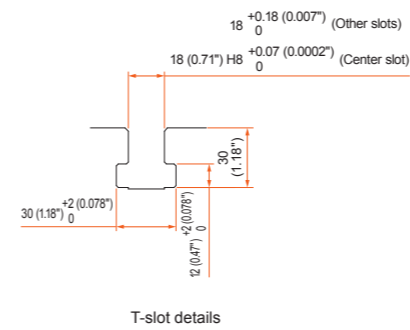
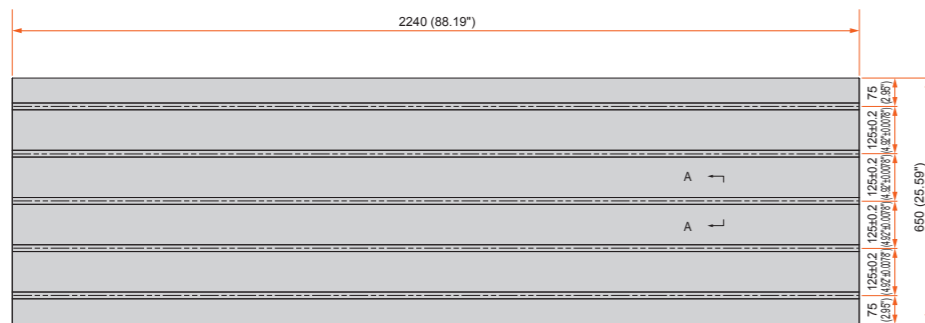

Standard Machine Specifications

		MTV-515/40	MTV-655/60	MTV-655/80	MTV-815/80	MTV-815/120
Travel	X-axis stroke (table left / right)	1050 mm (41.33")	1500 mm (59.05")	2000 mm (78.74")	2032 mm (80")	3048 mm (120")
	Y-axis stroke (column back / forth)	510 mm (20.08")	650 mm (25.59")	650 mm (25.59")	810 mm (31.89")	810 mm (31.89")
	Z-axis stroke (spindle head up / down)	560 mm (22.05")	650 mm (25.59")	650 mm (25.59")	750 mm (29.53")	750 mm (29.53")
Table	Distance from table top to spindle nose	200~760 mm (7.87"~29.92")	200~850 mm (7.87"~33.46")	200~850 mm (7.87"~33.46")	200~950 mm (7.87"~37.40")	200~950 mm (7.87"~37.40")
	Table size	1300 mm×550 mm (51.18"×21.65")	1740 mm×650 mm (68.50"×25.59")	2240 mm×650 mm (88.18"×25.59")	2240 mm×810 mm (88.19"×31.89")	3240 mm×810 mm (127.56"×31.89")
	Table load capacity (evenly distributed)	1500 kg (3307 lbs)	2000 kg (4409 lbs)	2500 kg (5511 lbs)	3000kg (6614 lbs)	3000kg (6614 lbs)
	Table surface configuration	18 mm (0.71") T-slot×5, 100 mm (3.94") pitch	18 mm (0.71") T-slot×5, 125 mm (4.92") pitch	18 mm (0.71") T-slot×5, 125 mm (4.92") pitch	18 mm (0.71") T-slot×5, 150 mm (5.91") pitch	
Spindle	Speed	6000 rpm			6000 rpm	
	Spindle speed range	2 steps			2 steps	
	Spindle taper	No.50			No.50	
	Spindle bearing ID	100 mm (3.94")			100 mm (3.94")	
Feedrate	Rapid traverse rate (X, Y, Z-axes)	26000 / 26000 / 20000 mm/min (1024 / 1024 / 787 IPM)		26000 / 26000 / 20000 mm/min (1024 / 1024 / 787 IPM)	24000 / 24000 / 18000 mm/min (945 / 945 / 709 IPM)	
	Cutting feedrate (X, Y, Z-axes)	8000 mm/min (315 IPM)			8000 mm/min (315 IPM)	
Automatic tool changer	Tool shank	No. 50			No. 50	
	Tool storage capacity	30			30	
	Max. tool diameter / length (from gauge line) / weight	ø125 mm (4.92") / 400 mm (15.74") / 20 kg (44 lbs)			ø125 mm (4.92") / 400 mm (15.75") / 20 kg (44 lbs)	
	Max. tool diameter with adjacent pockets empty	ø265 mm (10.43")		ø265 mm(10.43")	ø260 mm (10.24")	
	Tool selection method	Random selection, shortest path			Random selection, shortest path	
Tool change time (chip-to-chip)	5.5 sec.	6.0 sec.	6.0 sec.	6.5 sec.		
Power requirements	Spindle motor (40 % ED / 30 min. rating / cont. rating)	18.5 kW (25 HP) / 15.0 kW (20 HP)			18.5 kW (25 HP) / 15.0 kW (20 HP)	
	Power requirement (30 min. rating / cont. rating)	43.3 kVA / 38.4 kVA		44.2 kVA / 39.4 kVA	45.6 kVA / 40.7 kVA	48.2 kVA / 43.4 kVA
	Air supply	0.5 MPa (73 PSI) or more / 200 L/min (7.06 ft ³ /min) (ANR) or more			0.5 MPa (73 PSI) or more / 200 L/min (7.06 ft ³ /min) (ANR) or more	
Machine size	Height	2873 mm (111.1")	2993 mm (117.83")	2993 mm (117.83")	3143 mm (123.74")	
	Floor space requirement (MAZATROL SmoothC)	3445 mm×3900.2 mm (135.63"×153.55")	4445 mm×3987 mm (175.00"×156.97")	5545 mm×3987 mm (218.31"×156.97")	5685 mm×4096 mm (223.82"×161.26")	7775 mm×4096 mm (306.10"×161.26")
	Floor space requirement (MAZATROL SmoothG)	3445 mm×4200.3 mm (135.63"×165.37")	4445 mm×4287 mm (175.00"×168.78")	5545 mm×4287 mm (218.31"×168.78")	5685 mm×4396 mm (223.82"×173.07")	7775 mm×4396 mm (306.10"×173.07")
	Weight (CNC included)	8900 kg (19621 lbs)	11000 kg (24250 lbs)	12000 kg (26455 lbs)	14000 kg (30864 lbs)	15500 kg (34171 lbs)

Standard and Optional Equipment

● : Standard ○ : Option - : N/A

		MTV-515/40		MTV-655/60		MTV-655/80	
		MAZATROL SmoothG	MAZATROL SmoothC	MAZATROL SmoothG	MAZATROL SmoothC	MAZATROL SmoothG	MAZATROL SmoothC
Machine	Work light	●	●	●	●	●	●
	Additional work light (LED)	○	○	○	○	○	○
	30 tool chain type tool magazine	●	●	●	●	●	●
	60 tool chain type tool magazine	○	○	○	○	○	○
	Y-axis reference slot on table	○	○	○	○	○	○
	Big-Plus tool (#50)	○	○	○	○	○	○
	Manual pulse generator	○	○	○	○	○	○
	Ball screw core cooling (X, Y, Z-axes)	●	●	●	●	●	●
	Air line water filter	○	○	○	○	○	○
	Operator door interlock	●	●	●	●	●	●
	Total cover	●	●	●	●	●	●
Automation	Auto tool length measurement & tool breakage detection	○	○	○	○	○	○
	Mazak monitoring system B (optical) OMP60	○	○	○	○	○	○
	Preparation for Mazak monitoring system B / OMP60	○	○	○	○	○	○
	Absolute position detection	●	●	●	●	●	●
	Work air blast	○	○	○	○	○	○
	Auto power off	—	●	—	●	—	●
	Automatic power ON/OFF + warm-up operation	●	○	●	○	●	○
	Machining end buzzer	○	○	○	○	○	○
	Status light	○	○	○	○	○	○
	Status light (3 colors)	○	○	○	○	○	○
	Tool ID magazine operation panel (touch panel)	○	—	○	—	○	—
Tool retention stud with ID chip (#50 EUCHNER)	○	○	○	○	○	○	
Magazine operation panel (ID not compatible)	●	●	●	●	●	●	
Coolant	Coolant system	●	●	●	●	●	●
	Oil skimmer (RB-200)	○	○	○	○	○	○
	Oil mist coolant	○	○	○	○	○	○
	Mist collector (GP 1000)	○	○	—	—	—	—
	Mist collector (GP 2000)	—	—	○	○	○	○
	Coolant temperature control	○	○	○	○	○	○
	Handheld coolant nozzle	○	○	○	○	○	○
	Flood coolant 4.5 kg/cm ² (64 PSI), 30 L/min (8 gal/min)	○	○	○	○	○	○
	Air through spindle	○	○	○	○	○	○
	Coolant through spindle (5 kg/cm ² (7 PSI))	○	○	○	○	○	○
	Tap coolant fitting preparation (without holder)	○	○	○	○	○	○
	Niagara coolant	○	○	○	○	○	○
	Coolant through spindle (15 kg/cm ² (21 PSI)) preparation	○	○	○	○	○	○
	High pressure coolant through spindle (15 kg/cm ² (21 PSI))	○	○	○	○	○	○
	High pressure coolant through spindle (70 kg/cm ² (100 PSI))	○	○	○	○	○	○
	SUPERFLOW coolant system	○	○	○	○	○	○
Pressure switch for coolant through spindle	○	○	○	○	○	○	
Cover coolant	○	○	○	○	○	○	
Chip disposal	Front spiral conveyor	○	○	●	●	●	●
	Chip conveyor rear disposal (HINGE)	○	○	○	○	○	○
	Chip conveyor rear disposal (ConSep)	○	○	○	○	○	○
	Chip bucket (swing type)	○	○	○	○	○	○
	Chip bucket (fixed type)	○	○	○	○	○	○
Table	Sub table	○	○	○	○	○	○
	Manual (CD)	●	●	●	●	●	●
Others	Manual (CD)	●	●	●	●	●	●
	Additional M-code function	○	○	○	○	○	○

*When using high pressure coolant through spindle, optional top cover is required.

● : Standard ○ : Option - : N/A

		MTV-815/80		MTV-815/120	
		MAZATROL SmoothG	MAZATROL SmoothC	MAZATROL SmoothG	MAZATROL SmoothC
Machine	Work light	●	●	●	●
	30 tool chain type tool magazine	●	●	●	●
	60 tool chain type tool magazine	○	○	○	○
	Y-axis reference slot on table	○	○	○	○
	Big-Plus tool (#50)	○	○	○	○
	Manual pulse generator	○	○	○	○
	Ball screw core cooling (X, Y, Z-axes)	●	●	●	●
	Air line water filter	○	○	○	○
	Operator door interlock	●	●	●	●
	Total cover	●	●	●	●
	Automation	Auto tool length measurement & tool breakage detection	○	○	○
Mazak monitoring system B (optical) OMP60		○	○	○	○
Preparation for Mazak monitoring system B / OMP60		○	○	○	○
Absolute position detection		●	●	●	●
Work air blast		○	○	○	○
Auto power off		—	●	—	●
Automatic power ON/OFF + warm-up operation		●	○	●	○
Machining end buzzer		○	○	○	○
Status light		○	○	○	○
Status light (3 colors)		○	○	○	○
Tool ID magazine operation panel (touch panel)		○	—	○	—
Tool retention stud with ID chip (#50 EUCHNER)	○	○	○	○	
Magazine operation panel (ID not compatible)	●	●	●	●	
Coolant	Coolant system	●	●	●	●
	Oil skimmer (RB-200)	○	○	○	○
	Oil mist coolant	○	○	○	○
	Mist collector (GP 1000)	—	—	○	○
	Mist collector (GP 2000)	○	○	—	—
	Coolant temperature control	○	○	○	○
	Handheld coolant nozzle	○	○	○	○
	Flood coolant 4.5 kg/cm ² (64 PSI), 30 L/min (8 gal/min)	○	○	○	○
	Air through spindle	○	○	○	○
	Coolant through spindle (5 kg/cm ² (7 PSI))	○	○	○	○
	Tap coolant fitting preparation (without holder)	○	○	○	○
	Niagara coolant	○	○	○	○
	Coolant through spindle (15 kg/cm ² (21 PSI)) preparation	○	○	○	○
	High pressure coolant through spindle (15 kg/cm ² (21 PSI))	○	○	○	○
	High pressure coolant through spindle (70 kg/cm ² (100 PSI))	○	○	○	○
	SUPERFLOW coolant system	○	○	○	○
Pressure switch for coolant through spindle	○	○	○	○	
Cover coolant	○	○	○	○	
Chip disposal	Front spiral conveyor	●	●	●	●
	Chip conveyor rear disposal (HINGE)	○	○	○	○
	Chip conveyor rear disposal (ConSep)	○	○	○	○
	Chip bucket (swing type)	○	○	○	○
	Chip bucket (fixed type)	○	○	○	○
Table	Sub table	○	○	○	○
	Manual (CD)	●	●	●	●
Others	Manual (CD)	●	●	●	●
	Additional M-code function	○	○	○	○

*When using high pressure coolant through spindle, optional top cover is required.

MAZATROL SmoothG Specifications

	MAZATROL	EIA
Number of controlled axes	Simultaneous 4 axes	
Least input increment	0.0001 mm, 0.00001 inch, 0.0001 deg	
High speed, high precision control	Shape error designation, Smooth corner control, Rapid traverse overlap, Rotary axis shape compensation	Shape error designation, Smooth corner control, Rapid traverse overlap, Rotary axis shape compensation, High-speed machining mode, High-speed smoothing control function
Interpolation	Positioning (Linear interpolation), Positioning (Independent interpolation), Linear interpolation, Circular interpolation, Synchronized spindle tapping*	Positioning (Linear interpolation), Positioning (Independent interpolation), Linear interpolation, Circular interpolation, Spiral interpolation, Helical interpolation, Cylindrical coordinate interpolation*, Fine spline interpolation*, NURBS interpolation*, Polar coordinate interpolation*, Synchronized spindle tapping*
Feedrate	Rapid traverse, Cutting feed, Cutting feed (per minute), Cutting feed (per revolution), Dwell (specified time, specified number of rotation), Rapid traverse override, Cutting feed override, G0 speed variable control, Feedrate clamp, Variable acceleration / deceleration control, Constant control for G0 tilting*	Rapid traverse, Cutting feed, Cutting feed (per minute), Cutting feed (per revolution), Inverse time feed, Dwell (specified time, specified number of rotation), Rapid traverse override, Cutting feed override, G0 speed variable control, Feedrate clamp, Time constant changing for G1, Variable acceleration / deceleration control, Constant control for G0 tilting*
Program registration	Max. number of programs : 960, Program storage : 2 MB, Program storage expansion : 8 MB*, Program storage expansion : 32 MB*	
Control display	Display : 19" touch panel, Resolution : SXGA	
Spindle functions	S code output, Spindle speed clamp, Spindle speed override, Spindle speed reaching detection, Multiple position orient, Constant surface speed, Spindle speed command with decimal digits, Synchronized spindle control, Max. speed control for spindle	
Tool functions	Tool offset pairs : 4000, T code output for tool number, Tool life monitoring (time), Tool life monitoring (number of machined workpieces)	Tool offset pairs : 4000, T code output for tool number, T code output for group number, Tool life monitoring (time), Tool life monitoring (number of machined workpieces)
Miscellaneous functions	M code output, Simultaneous output of multiple M codes	
Tool offset functions	Tool position offset, Tool length offset, Tool diameter / tool nose R offset, Tool wear offset	
Coordinate system	Machine coordinate system, Work coordinate system, Local coordinate system, Additional work coordinates (300 set)	
Machine functions	—	Shaping function*, Dynamic compensation II*
Machine compensation	G0 / G1 independent backlash compensation, Pitch error compensation	
Protection functions	Emergency stop, Interlock, Stroke check before travelling, Retraction function for the vertical axis, SAFETY SHIELD (manual mode), SAFETY SHIELD (automatic mode)*, VOICE ADVISER	
Automatic operation mode	Memory operation	Memory operation, Tape operation, MDI operation, EtherNet operation*
Automatic operation control	Optional stop, Dry run, Automatic handle control, MDI control, TPS, Restart, Machine lock	Optional block skip, Optional stop, Dry run, Automatic handle control, MDI control, TPS, Restart, Restart 2, Collation stop, Machine lock
Manual measuring functions	Tool length and tip teach, Touch sensor coordinates measurement, Workpiece offset measurement, WPC coordinate measurement, Measurement on machine	Tool length and tip teach, Tool offset teach, Touch sensor coordinates measurement, Workpiece offset measurement, WPC coordinate measurement, Measurement on machine
Automatic measuring functions	WPC coordinate measurement, Automatic tool length measurement, Sensor calibration, Tool breakage detection, External tool breakage detection*	Automatic tool length measurement, Sensor calibration, Tool breakage detection, External tool breakage detection*
MDI measurement	Partial auto tool length measurement, Auto tool length measurement, Coordinate measurement	
Interface	PROFIBUS-DP*, EtherNet I/P*, CC-Link*	
Card interface	SD card interface, USB	
EtherNet	10 M / 100 M / 1 Gbps	

* Option

MAZATROL SmoothC Specifications

	MAZATROL	EIA
Number of controlled axes	Simultaneous 4 axes	
Least input increment	0.0001 mm, 0.00001 inch, 0.0001 deg	
High speed, high precision control	Shape error designation, Smooth corner control, Rapid traverse overlap, Rotary axis shape compensation	Shape error designation, Smooth corner control, Rapid traverse overlap, Rotary axis shape compensation, High-speed machining mode, High-speed smoothing control function
Interpolation	Positioning (Linear interpolation), Positioning (Independent interpolation), Linear interpolation, Circular interpolation, Synchronized spindle tapping*	Positioning (Linear interpolation), Positioning (Independent interpolation), Linear interpolation, Circular interpolation, Spiral interpolation, Helical interpolation, Cylindrical coordinate interpolation*, Fine spline interpolation*, NURBS interpolation*, Polar coordinate interpolation*, Synchronized spindle tapping*
Feedrate	Rapid traverse, Cutting feed, Cutting feed (per minute), Cutting feed (per revolution), Dwell (specified time, specified number of rotation), Rapid traverse override, Cutting feed override, G0 speed variable control, Feedrate clamp, Variable acceleration / deceleration control, Constant control for G0 tilting*	Rapid traverse, Cutting feed, Cutting feed (per minute), Inverse time feed, Cutting feed (per revolution), Dwell (specified time, specified number of rotation), Rapid traverse override, Cutting feed override, G0 speed variable control, Feedrate clamp, Time constant changing for G1, Variable acceleration / deceleration control, Constant control for G0 tilting*
Program registration	Max. number of programs : 960, Program storage : 2 MB, Program storage expansion : 8 MB*, Program storage expansion : 32 MB*	
Control display	Display : 10.4", Resolution : VGA	
Spindle functions	S code output, Spindle speed clamp, Spindle speed override, Spindle speed reaching detection, Multiple position orient, Constant surface speed, Spindle speed command with decimal digits, Synchronized spindle control, Max. speed control for spindle	
Tool functions	Tool offset pairs : 4000, T code output for tool number, Tool life monitoring (time), Tool life monitoring (number of machined workpieces)	Tool offset pairs : 4000, T code output for tool number, T code output for group number, Tool life monitoring (time), Tool life monitoring (number of machined workpieces)
Miscellaneous functions	M code output, Simultaneous output of multiple M codes	
Tool offset functions	Tool position offset, Tool length offset, Tool diameter / tool nose R offset, Tool wear offset	
Coordinate system	Machine coordinate system, Work coordinate system, Local coordinate system, Additional work coordinates (300 set)	
Machine functions	—	Shaping function*, Dynamic compensation II*
Machine compensation	G0 / G1 independent backlash compensation, Pitch error compensation	
Protection functions	Emergency stop, Interlock, Stroke check before travelling, Retraction function for the vertical axis	
Automatic operation mode	Memory operation	Memory operation, Tape operation, MDI operation, EtherNet operation*
Automatic operation control	Optional stop, Dry run, Automatic handle control, MDI control, TPS, Restart, Machine lock	Optional block skip, Optional stop, Dry run, Automatic handle control, MDI control, TPS, Restart, Restart 2, Collation stop, Machine lock
Manual measuring functions	Tool length and tip teach, Touch sensor coordinates measurement, Workpiece offset measurement, WPC coordinate measurement, Measurement on machine	Tool length and tip teach, Tool offset teach, Touch sensor coordinates measurement, Workpiece offset measurement, WPC coordinate measurement, Measurement on machine
Automatic measuring functions	WPC coordinate measurement, Automatic tool length measurement, Sensor calibration, Tool breakage detection, External tool breakage detection*	Automatic tool length measurement, Sensor calibration, Tool breakage detection, External tool breakage detection*
MDI measurement	Partial auto tool length measurement, Auto tool length measurement, Coordinate measurement	
Interface	PROFIBUS-DP*, EtherNet I/P*, CC-Link*	
Card interface	SD card interface, USB	
EtherNet	10 M / 100 M / 1 Gbps	

* Option