

Mazak

VORTEX e-V SERIES



VORTEX e-V
S E R I E S

1250V/8
1250V/8S
1600V/10
1600V/10S

YAMAZAKI MAZAK CORPORATION

1-131 Takeda, Oguchi-cho, Niwa-gun, Aichi-pref., Japan
TEL : +(81)587-95-1131 FAX : +(81)587-95-2717

www.mazak.com

- Specifications are subject to change without notice.
- This product is subject to all applicable export control laws and regulations.
- The accuracy data and other data presented in this catalogue were obtained under specific conditions. They may not be duplicated under different conditions. (room temperature, workpiece materials, tool material, cutting conditions, etc.)



Advanced features of the MAZATROL SmoothX CNC

Touch screen operation

— Operates similar to your smart phone / tablet

PC with Windows® 8 embedded OS

Fastest CNC in the world

— Latest hardware and software for unprecedented speed and precision

High precision machining of complex counters at high speed feedrates

Smooth graphical user interface and support functions for unsurpassed ease of operation

Easily configure machine parameters for different workpiece materials and applications requirements

MTConnect®

— Convenient networking

Windows is registered trademark of Microsoft Corporation in the United States and other countries.
MTConnect is a registered trademark of AMT in the United States and other countries.



MAZATROL SMOOTHX

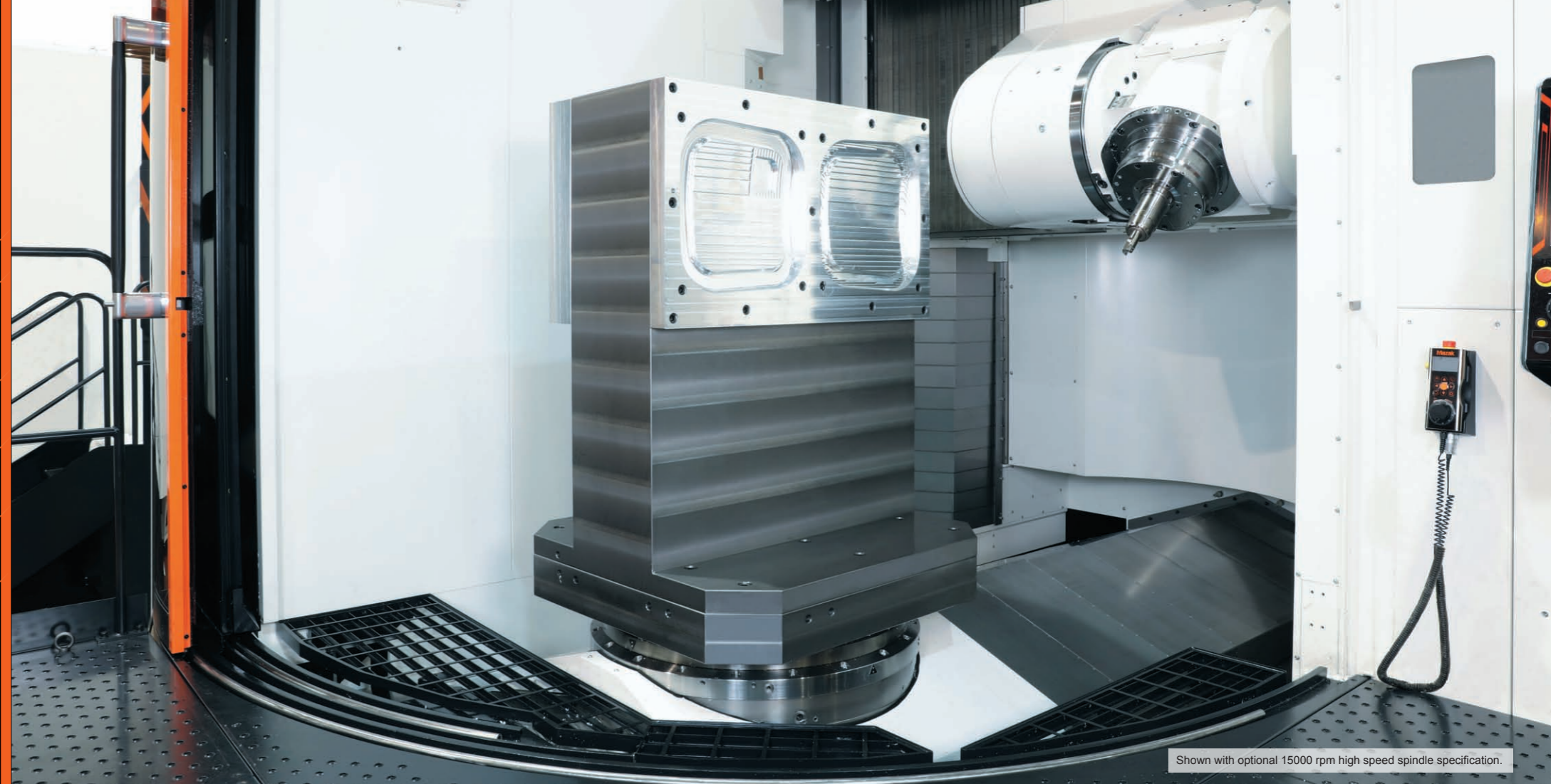

Shown with optional 15000 rpm high speed spindle specification.

High-performance simultaneous 5-axis machining center designed for exceptional versatility and efficiency



Innovative support for operators

ergonomics

Ease of operation

eco-friendly

Designed with environmental considerations

VORTEX e-V SERIES

Simultaneous 5-axis Vertical Machining Centers

- Double column ensures high-accuracy machining in large working area
- MAZATROL SmoothX CNC together with linear roller guides ensure high speed feedrates with high accuracy
- Versatile multi-tasking machining thanks to 0.0001° positioning of B and C-axes
- Wide range of spindle specifications: standard 10000 rpm, high torque 5000 rpm for difficult to machine materials, and high speed 15000 rpm

Extensive Series Range

Designed to meet the machining requirements of a wide range of large workpieces



Shown with optional 15000 rpm milling spindle, 84 tool magazine and status light (3 colors)



Shown with optional 84 tool magazine

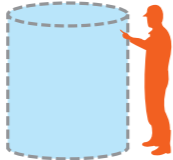
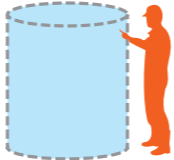
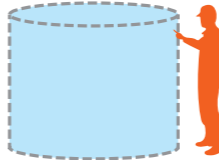
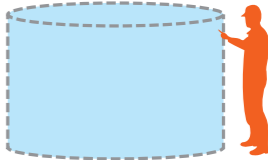

Shown with optional 84 tool magazine and status light (3 colors)

VORTEX	e-1250V/8 [2 pallet changer]	e-1250V/8S [Single table]	e-1600V/10 [2 pallet changer]	e-1600V/10S [Single table]
Max. workpiece diameter × Max. workpiece height	ø1450 mm × 1600 mm 	ø1500 mm × 1655 mm 	ø2050 mm × 1600 mm 	ø2300 mm × 1669 mm 
Max. load (including pallet)	2700 kg	4000 kg	5000 kg	7000 kg
Pallet size <small>* option</small>	□800 mm*, □1000 mm*, ø1000 mm*	ø800 mm*, ø1000 mm*, ø1250 mm*	□1000 mm*, ø1400 mm*	ø1250 mm*, ø1400 mm*, ø1500 mm*, ø1650 mm*
Stroke (X / Y / Z) (B / C)	1875 mm / 1250 mm / 1345 mm 150° / 360°	1875 mm / 1250 mm / 1345 mm 150° / 360°	2315 mm / 1600 mm / 1345 mm 150° / 360°	2165 mm / 1600 mm / 1345 mm 150° / 360°

X-axis stroke diagram Unit : mm

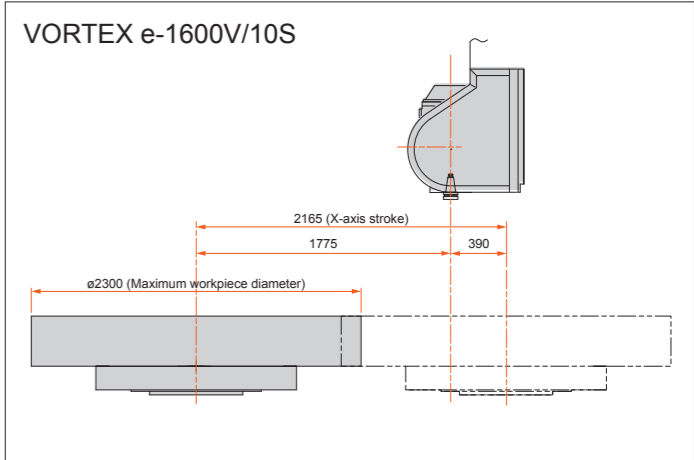
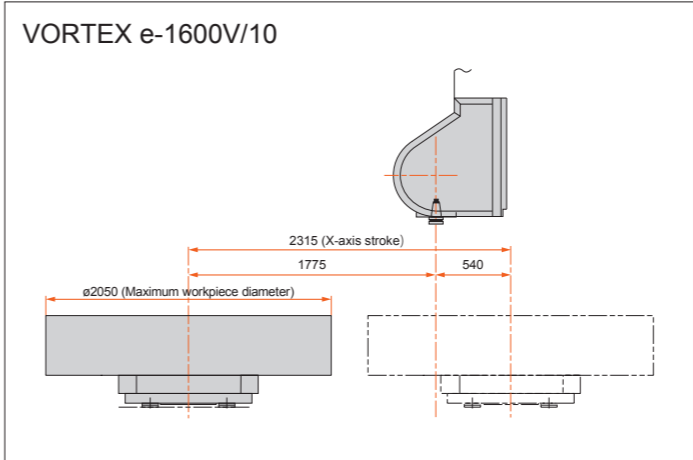
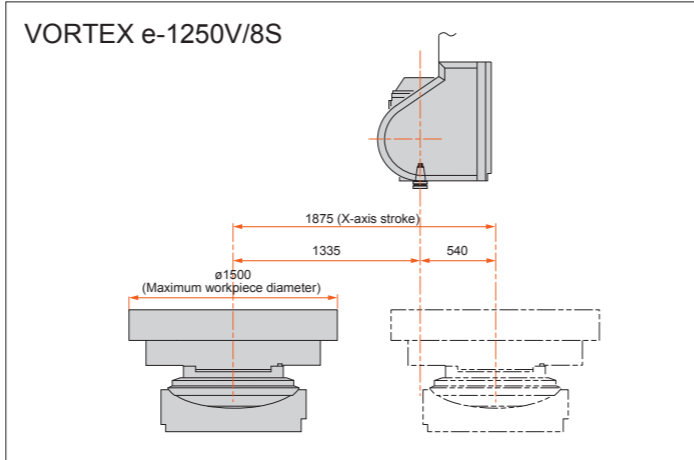
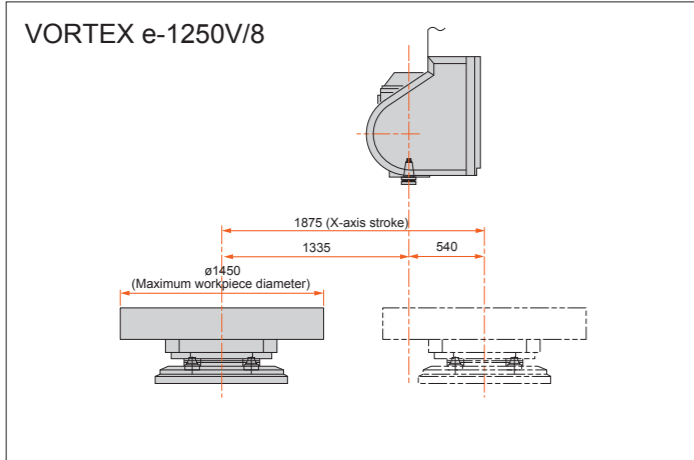

Higher Accuracy

High rigidity construction for high accuracy machining

Prevention of temperature change — milling spindle cooling

Temperature controlled cooling oil circulates through the milling spindle headstock to prevent heat displacement.

Roller gear cam utilized by B-axis

Elimination of backlash ensures high accuracy and high efficiency machining. (over the rotary positioning range of 150 degrees, positioning accuracy is two times better than the ISO standard)

Direct drive motor

A direct drive motor is used for C-axis operations. Since this eliminates a drive system made of belts and gears — there is no vibration, heat generation and backlash, high accuracy machining is realized.

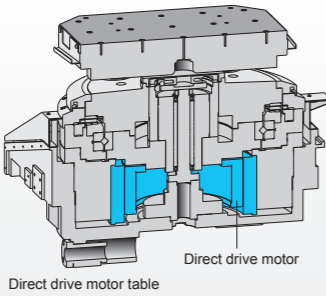

Precision table clamping

The pallet and table are clamped on taper cones to ensure high-rigidity and high accuracy positioning repeatability during pallet changes.

Single table e-1250V/8S and e-1600V/10S: tables are bolted to machine base.

Ball screw core cooling

Temperature controlled cooling oil circulates through the ball screw cores to ensure stable machining accuracy over extended periods of high speed operation.

Rigid, stable column

The column shape and weight distribution have been thoroughly analyzed so that the center of gravity is located to provide exceptional rigidity and stability.

Linear roller guides utilized on the X-, Y-, and Z-axes

Linear roller guides on the X-, Y-, and Z-axes are utilized by the VORTEX e-V series in order to provide high-accuracy and heavy duty machining.

High rigidity base

Rigidity is ensured thanks to the wide base with thick walls and optimized rib layout.

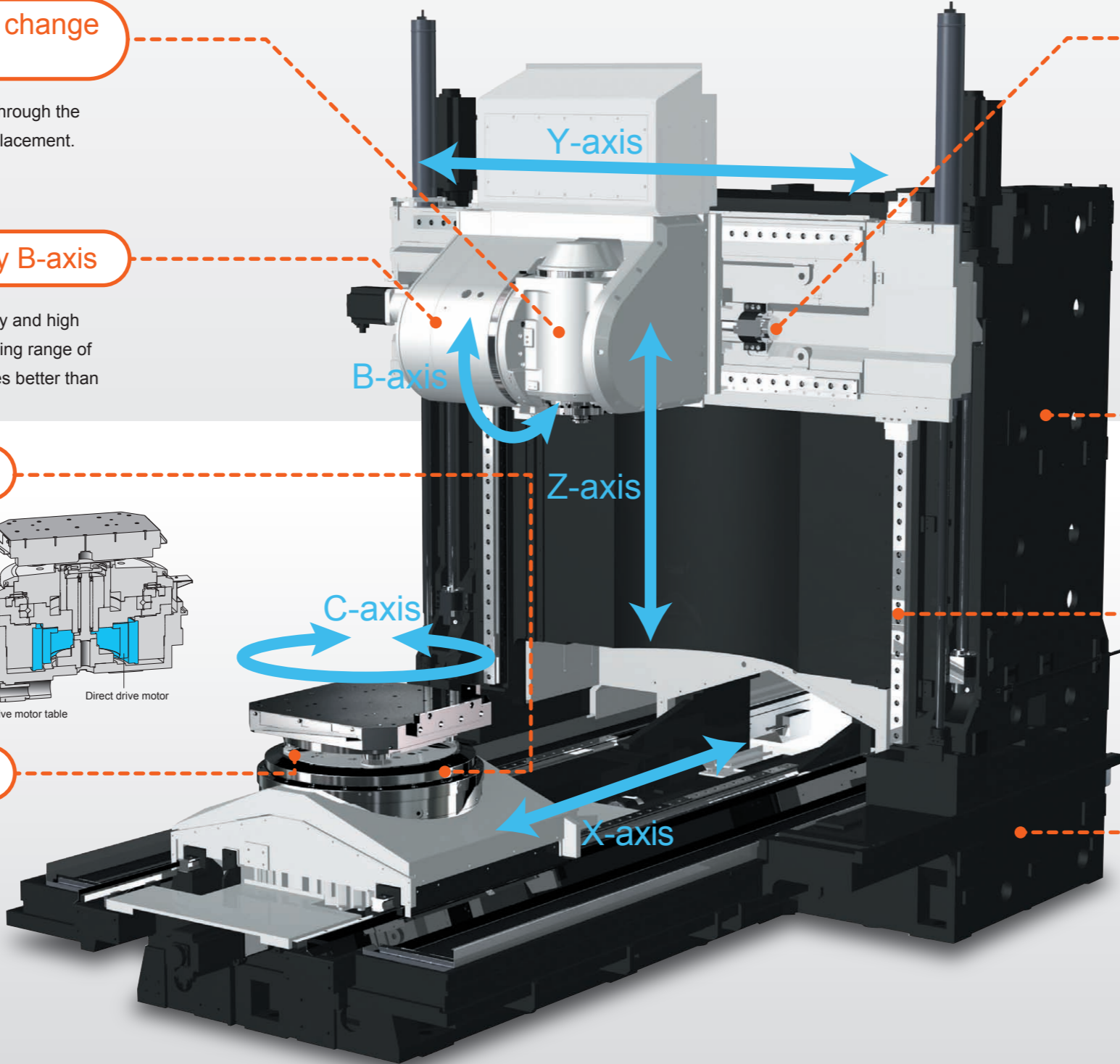

Higher Productivity



Enhanced milling performance for high productivity

High speed, high output milling spindle

The spindle has a standard top speed of 10000 rpm with a high-speed 15000 rpm spindle and high-torque 5000 rpm spindle optionally available.

Machining example - Standard specification milling spindle

Material removal rate	1092 cc/min	
Material	S45C	
Tool	Face mill ϕ 160 mm, 8 teeth	
Cutting conditions	Spindle speed	500 rpm
	Cutting speed	250 m/rpm
	Depth of cut	4.2 mm
	Feed / tooth	0.45 mm/tooth

Integral spindle/motor

The integral spindle/motor (standard 10000 rpm spindle specification and optional 5000 rpm and 15000 rpm spindle specifications) eliminates a transmission utilizing belts and gears to ensure high efficiency, high accuracy machining as well as exceptional surface finishes.

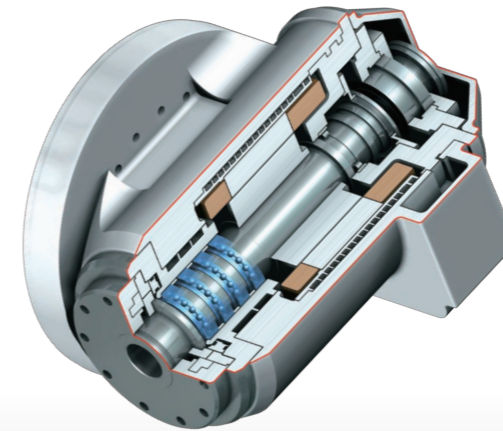

B-axis tilting range 150°

The B-axis tilting range 150° (-30° ~ 120°) is driven by a roller gear cam without any backlash to ensure high accuracy.

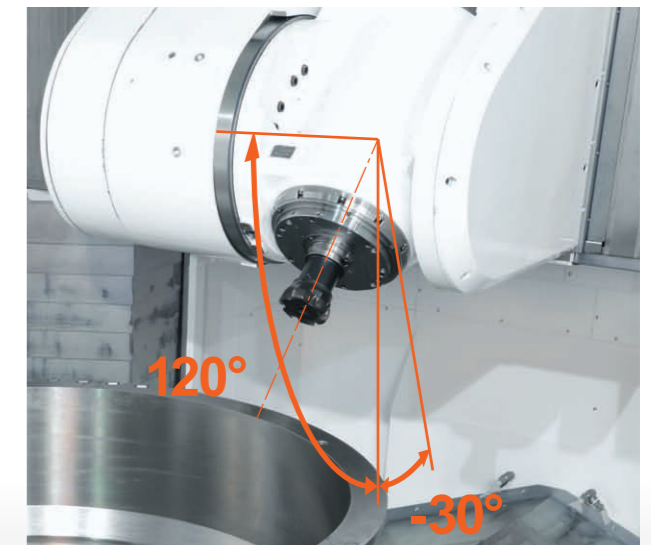

10000 rpm milling spindle

Speed	10000 rpm
Output (40 % ED / cont. rating)	AC 37 kW (50 HP) / AC 30 kW (40 HP)
Max. torque (40 % ED / cont. rating)	260 N·m / 191 N·m

Output / torque diagram

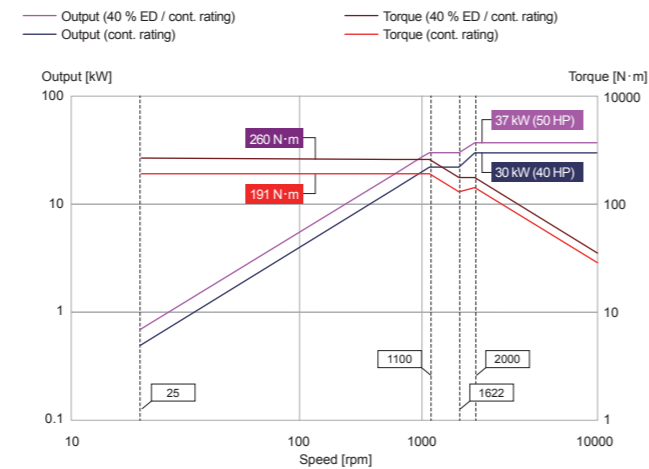

High torque 5000 rpm milling spindle OPTION

Speed	5000 rpm
Output (40 % ED / cont. rating)	AC 37 kW (50 HP) / AC 30 kW (40 HP)
Max. torque (40 % ED / cont. rating)	667 N·m / 500 N·m

Output / torque diagram

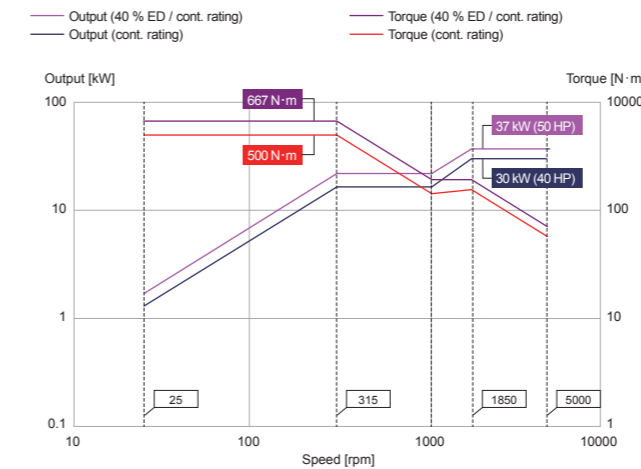

High speed 15000 rpm milling spindle OPTION

Speed	15000 rpm
Output (40 % ED / cont. rating)	AC 56 kW (75 HP) / AC 45 kW (60 HP)
Max. torque (40 % ED / cont. rating)	143 N·m / 118 N·m

Note: The distance from the B axis center of rotation to the tool gauge line is 350mm - the machining area is reduced by 50mm compared to the standard spindle.

Output / torque diagram

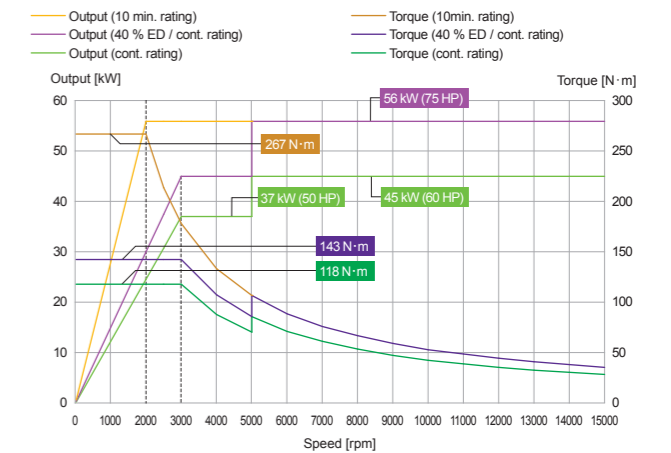

Higher Productivity

Direct drive motor table

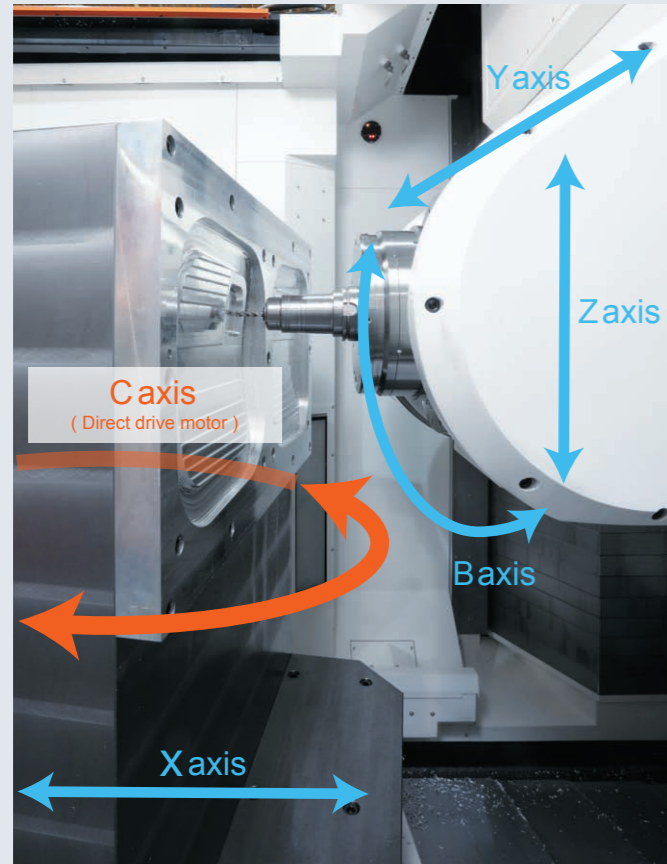

Shown with optional 15000 rpm high speed spindle specification

Direct drive table motor provides high performance 5-axis simultaneous machining. High torque specification is optionally available for heavy duty cutting.

Direct drive motor table specification

	e-1250V/8, e-1250V/8S	e-1600V/10, e-1600V/10S
Least input increment (C axis)	0.0001°	
Rapid traverse rate (C axis)	25 rpm	20 rpm
90° indexing time	1.1 sec	1.4 sec
Contouring torque	3180 N·m [5810 N·m : High-torque specification (option)]	

Tool magazine capacities available for any production requirement

High speed, high rigidity automatic tool changer

The automatic tool changer is designed for reliability and performs tool changes at high speed – including heavy tools as well.

Rack type tool magazine

Tools are stored vertically in racks resulting in a small space requirement for any tool storage capacity rack magazine. High speed and smooth tool loader movement reduces tool waiting time and vibration preventing any effect on machined surfaces. The 84 tool and 120 tool rack magazines can be expanded after the initial installation.



Standard 42 tool rack magazine

Tool storage	42 tools* (standard)	84 tools (option)	120 tools (option)	162 tools (option)
Tool selection method	Random selection	Random selection	Random selection	Random selection
Available tool capacity expansion	—	126 tools / 168 tools	162 tools	—

* 650 mm long tools can be stored on the bottom rack. The top and middle racks can store tools up to 500 mm long.

TOOL HIVE OPTION

The TOOL HIVE can store more than 180 tools in a small space. Operation and tool data editing can be performed on the TOOL HIVE TERMINAL control panel to reduce the time required for tool setup. The TOOL HIVE tool storage capacity can be expanded after the initial installation.

TOOL HIVE TERMINAL



240 tool TOOL HIVE magazine

Higher Productivity

2 pallet changer for reduced setup time

2 pallet changer

Rotary type 2 pallet changer is standard equipment. Workpiece loading and setup can be performed during machining to increase productivity.

Loading station rotation

Pallet at loading station is turned by motor for ease of setup. Standard equipment for the e-1600V/10, and optionally available for the e-1250V/8.

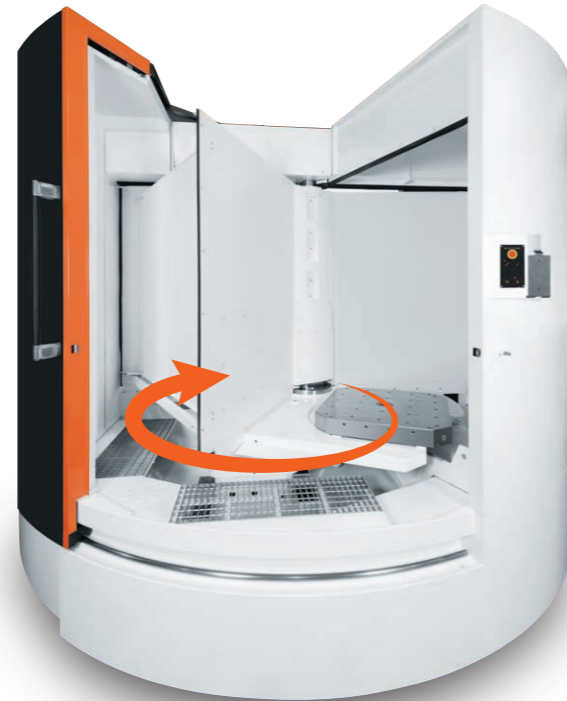

A variety of pallets / chucks is available to meet any machining requirement OPTION

Wide variety of chucks, pallets and face plates are optionally available

Machines	Tapped square pallet with location bore		Tapped round pallet with location bore			3 jaw scroll chuck	
	□800 mm	□1000 mm	∅1000 mm	∅1250 mm	∅1400 mm	∅1000 mm	∅1400 mm
e-1250V/8	○	○	○	—	—	○	—
e-1250V/8S	○	○	○	○	—	○	—
e-1600V/10	—	○	—	○	○	—	○
e-1600V/10S	—	○	—	○	○	—	○

Machines	Face plate with jaws				4-jaw independent chuck	
	∅800 mm	∅1000 mm	∅1250 mm	∅1400 mm	∅1000 mm	∅1400 mm
e-1250V/8	—	○	—	—	○	—
e-1250V/8S	○	○	○	—	○	—
e-1600V/10	—	—	—	○	—	○
e-1600V/10S	—	—	—	○	—	○

Note: Single table e-1250V/8S and e-1600V/10S; tables are bolted to machine base.

○ : Available — : Not available

Remote manual pulse generator

The remote manual pulse generator provides convenient operation when the operator is not close to the CNC operation panel. Its display shows the position display and the machine coordinate values. 4 different positions can be registered in memory by the remote manual pulse generator. A wireless remote manual pulse generator is optionally available.

Note : Regulations for the wireless manual pulse generator vary by country.

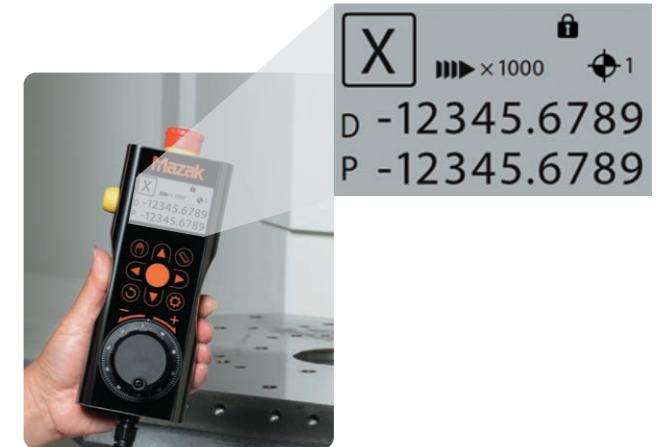

Tool magazine operation panel

The tool magazine operation panel is designed for increased ease of operation. Instead of having just a forward / reverse button for indexing the tool magazine and manually positioning the desired tool pocket, the pocket number or tool number can be input into the operation panel numeric keyboard and the desired pocket will be automatically brought into position. This is standard equipment for the different capacity tool magazines.



Tool magazine operation panel / Tool ID OPTION

The tool magazine operation panel is designed for increased ease of operation. Instead of having just a forward / reverse button for indexing the tool magazine and manually positioning the desired tool pocket, the pocket number or tool number can be input into the operation panel numeric keyboard and the desired pocket will be automatically brought into position. Additionally, tool data is displayed on this panel eliminating trips back to the machine CNC. By touching the tool data, the tool magazine will be indexed to the selected tool. The sort key quickly shows which tool pockets are empty.

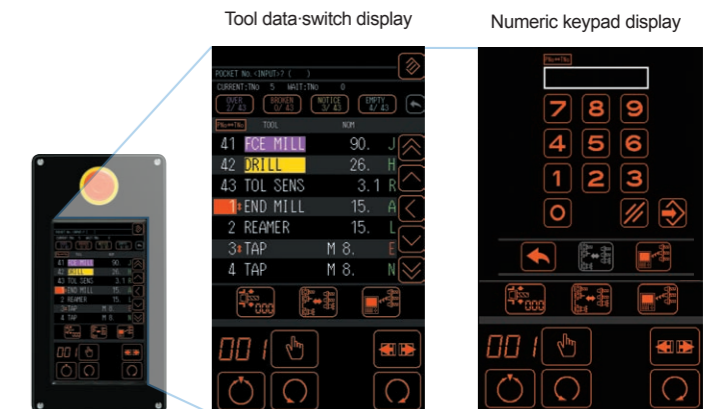

Ergonomics

Design focus on ergonomics provides unsurpassed ease of operation

Large window

The large windows on the 2 pallet changer cover door allow the operator to easily see the status of the workpiece in the setup station.



Convenient workpiece loading / unloading

An over head crane can be easily used for the loading / unloading of heavy workpieces and fixtures.



Large window

The large front window allows the operator to easily monitor workpiece machining.



2 pallet changer

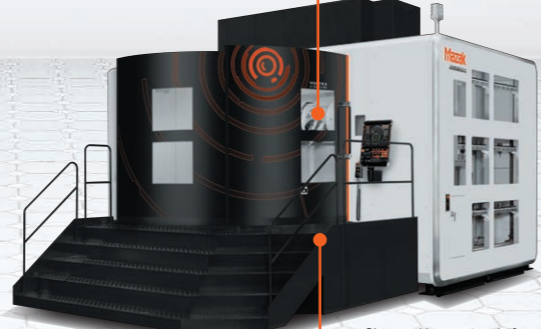

Single table

Shown with operator platform, 84 tool magazine and status light (3 colors) (option)

Convenient access to machining area

Steps outside the machine and inside the machine are standard equipment to provide convenient access to the operator.

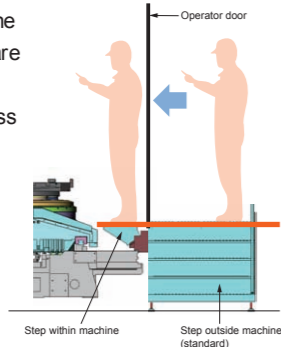

Convenient access

The step inside the machining area is the same height as the external platform providing excellent accessibility for workpiece or tool inspection.

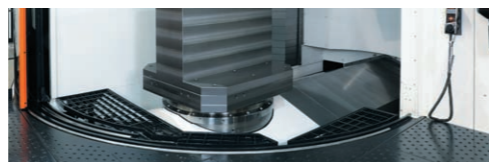

Convenient location of tool magazine

The tool magazine is located next to the CNC operation panel to significantly reduce the distance the operator must cover for machine setup.

2 pallet changer
: Operation area

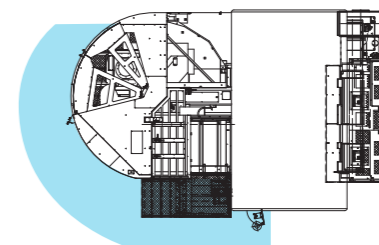

Single table
: Operation area

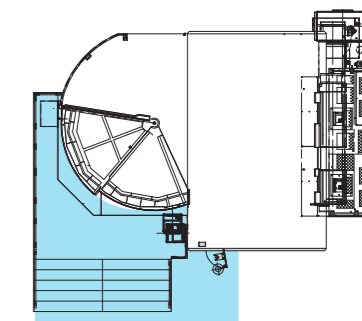

Adjustable CNC Touch Panel

Operation touch panel can be tilted to the optimum position for any operator's height to ensure ease of operation.



Rotation 90°



Tilt 45°

Centralized location

All the items that require frequent access, such as hydraulic and pneumatic valves and lubrication inlets, are at the same location to make daily maintenance easier.



ergonomics

Intelligent Machine



Yamazaki Mazak has developed a variety of functions for the improvement of productivity, high accuracy machining and operator support. A variety of unique technologies has been developed that incorporate the expertise of experienced machine operators that realizes unsurpassed productivity and higher accuracy machining.



Advanced Intelligent+ Functions

A variety of Intelligent+ Functions provides incomparable operator support for exceptional ease of operation and the optimum machine efficiency.

Set up

Machine Interference Prevention
INTELLIGENT SAFETY SHIELD
SS+

When an operator manually moves the machine axes for setup, tool measurement or changing inserts, the CNC shows a synchronized 3D model on the display for checking machine interference. If any machine interference occurs, the machine motion automatically stops. This function is also effective during automatic operation.

Verbal Message System
MAZAK VOICE ADVISER
MVA+

Verbal support for machine setup and safe conditions confirmation

Machining

Convenient Parameter Setting and Fine Tuning Function
SMOOTH MACHINING CONFIGURATION
SMC+

Machining time, finished surface smoothness and machining shape can be adjusted for improved productivity

Variable Acceleration Control Function
VARIABLE ACCELERATION CONTROL
VAC
Variable acceleration control is a new function which permits the faster acceleration capability of linear axes to be used whenever possible. The slower acceleration of the rotary axes is not used for all program commands, resulting in faster machining cycle times.

Minimized Vibration
ACTIVE VIBRATION CONTROL
AVC
Machine vibration can be reduced to perform excellent machining accuracy and high-speed machining.



Maintenance

Comprehensive Spindle Monitoring
INTELLIGENT PERFORMANCE SPINDLE
IPS+

The INTELLIGENT PERFORMANCE SPINDLE monitors a variety of properties such as temperature with sensors housed in the spindle and provides useful information to the operator. Thanks to this monitoring, production loss due to machine down time can be minimized.

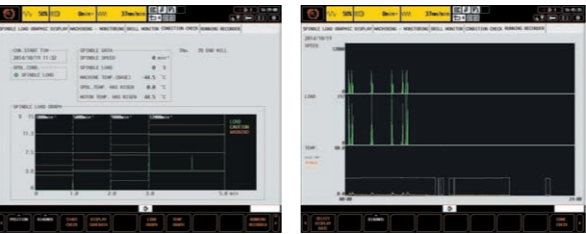

▲ Condition check
Temperature as well as the motor load can be displayed.

▲ Running recorder
Operation status of milling spindle (rpm / motor load) can be recorded for up to one year.

Comprehensive Maintenance Monitor
INTELLIGENT MAINTENANCE SUPPORT
IMS+

Useful information for improved preventative maintenance to prevent unexpected machine downtime.



Seamless Corner Control
SMOOTH CORNER CONTROL
SCC
Improved finished surfaces and reduced cycle times by optimized acceleration / deceleration when machining corners.

Other systems
Move to next command position after reaching current command position

SMOOTH CORNER CONTROL
Move to next command position within tolerance band

Heat Displacement Control
INTELLIGENT THERMAL SHIELD
ITS+

The INTELLIGENT THERMAL SHIELD is an automatic compensation system for room temperature changes, which realizes enhanced continuous machining accuracy. MAZAK has performed extensive testing in a variety of environments in a temperature controlled room and has used the results to develop a control system that automatically compensates for temperature changes in the machining area. Changes in the room temperature and compensation data are shown visually.



Temperature and compensation is displayed on screen. Operator can adjust compensation by looking at the data.

MAZATROL CNC System

The seventh generation MAZATROL CNC system
— the core of Smooth Technology

MAZATROL *SMOOTHX*

From setup to machining
— designed for unsurpassed ease of operation



Three color status indicator
Machining status is indicated by three colors.
Green: automatic operation mode
Yellow: Machining completion
Red: Alarm

19" touch panel
Touch panel operation
— similar to your smartphone or tablet

USB port
Interface for peripheral equipment
USB-1.0+2.0 standard.

SD card slot
Transfer program and tool data.

Operation switches
Large switches
— color changes from orange to green when turned on.

Dials
For frequently-used axes selection and feedrate changes.

New interface with touch operation ensures convenient data processing
— programming, confirmation, editing, and tool data registration

Process home screens

Five different home process screens
— each home screen displays the appropriate data in an easy-to-understand manner. Icons can be touched in each process display for additional screen displays.

Programming



Tool data

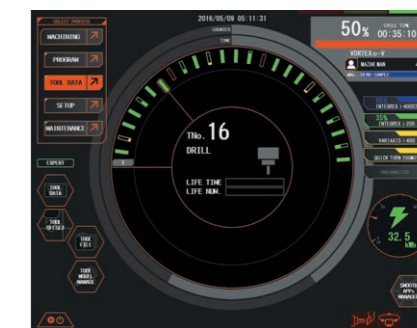

Setup

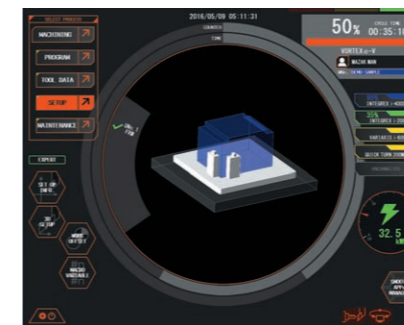

Machining

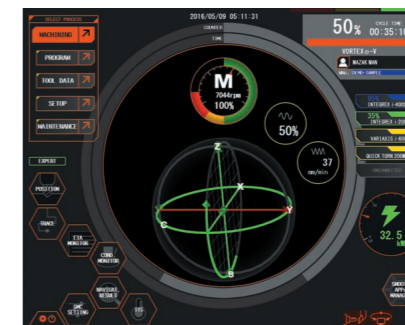

Maintenance



Pop-up windows

Values and items can easily be input/selected on pop-up windows.

Side menu

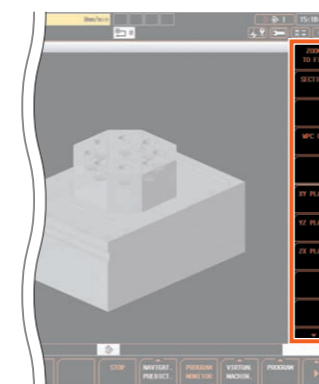

List menu



Screen key board



MAZATROL CNC System

Visible programming screen

QUICK EIA

Program, process list and 3D tool path display are linked to each other. Visible search on touch screen can reduce the time for program checking.

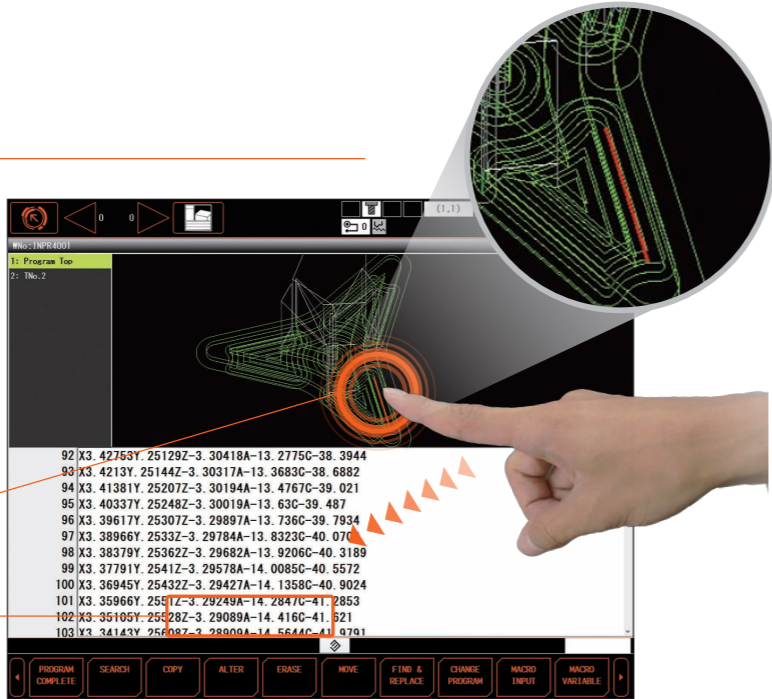

Selecting tool path by touching the screen.

Moving to the corresponding EIA program line.

QUICK MAZATROL

MAZATROL program, unit list and 3D workpiece shape are linked to each other. After defining a machining unit in a MAZATROL program, the 3D shape is immediately displayed to easily and quickly check for any programming error.

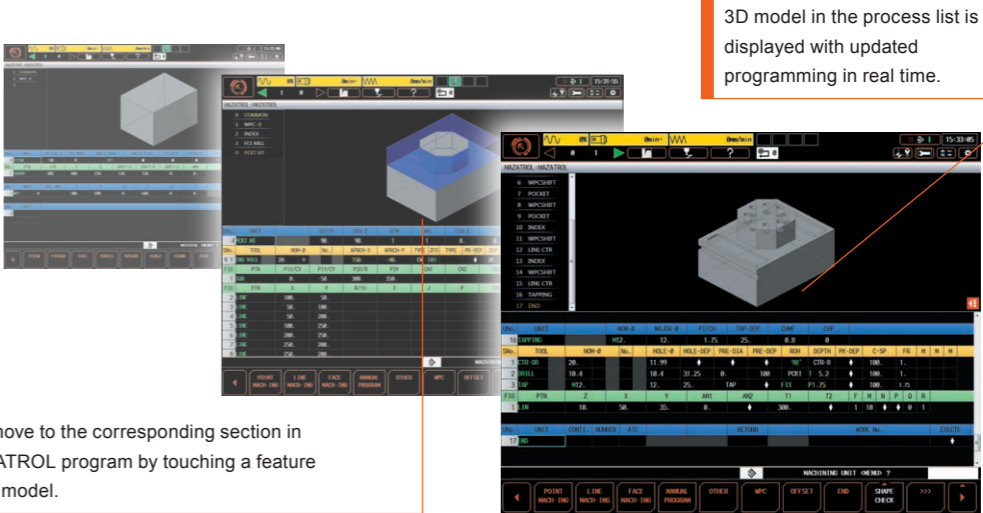

3D model in the process list is displayed with updated programming in real time.

Quickly move to the corresponding section in the MAZATROL program by touching a feature in the 3D model.

VIEW SURF

By analyzing tool path, any predictable failure on the finished surface can be visualized. Program modification can be done before machining to minimize the time for test cutting.

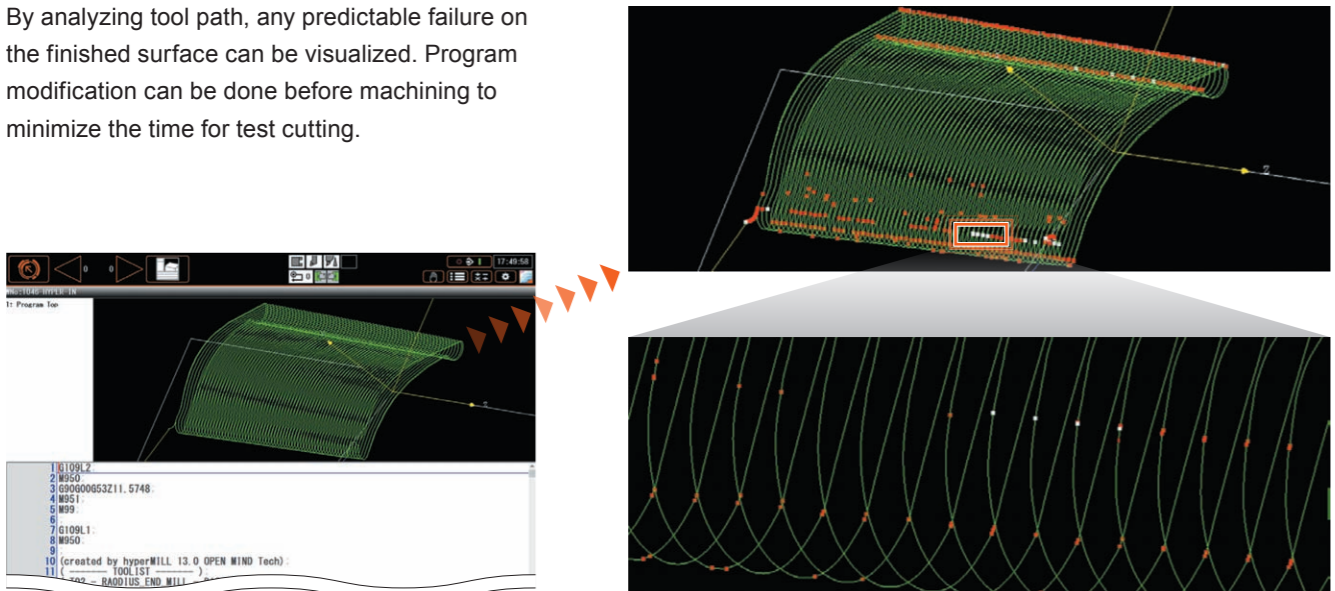

3D ASSIST

Workpiece and coordinates data can be imported from 3D CAD data to a MAZATROL program. No coordinate value inputs are required. Can reduce input errors and time for program checking.



Automatically input to MAZATROL program

CAD model importing

Shape selection

MAZATROL CNC System

Network integration

— convenient connection to automation equipment

Smooth Process Support Software for efficient factory management OPTION



Data sharing between SmoothX CNC and office PCs for improved production efficiency.



Networking to peripheral equipment OPTION

Convenient network connection to peripheral equipment thanks to industrial network standards

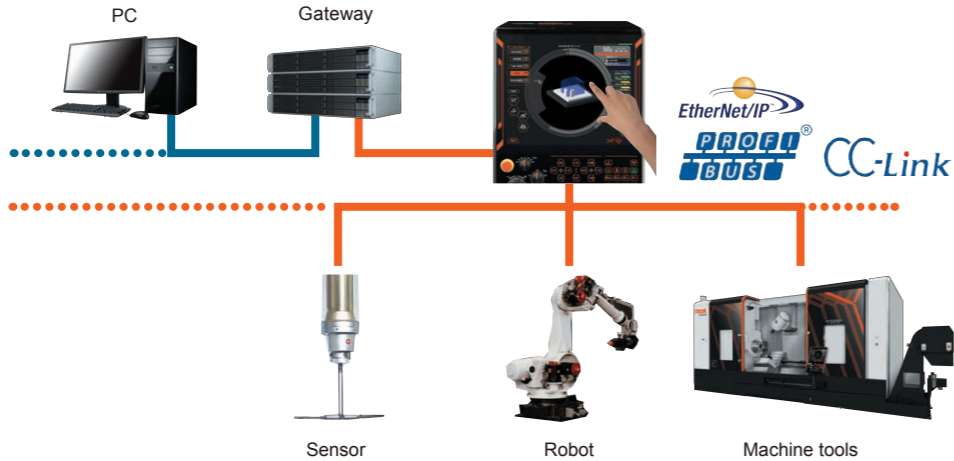

EtherNet/IP is a trademark of ODVA (Open Device Net Vendor Association).
 PROFIBUS is a trademark of PROFIBUS User Organization.
 MTConnect is a registered trademark of AMT (Association for Manufacturing Technology).

Factory Automation

Unmanned operation for enhanced productivity

The modular design of the PALLETECH conveniently allows more machines and increased pallet storage capacity to be added to the system after the initial installation in response to changing production requirements. The pallet stoker is available with one, two and three levels for large pallet storage capacity with small floor space requirements.



PALLETECH SYSTEM (shown with 1 level stoker with 6 pallets, loading station and one VORTEX)

		Minimum	Maximum
Machines		1	16
Number of pallets	1 level	6	240
	2 levels	12	240
Loading station(s)		1	8
Loading robot		1	1

Machine model	Pallet stoker	
	1 level	2 levels
e-1250V/8	○	○
e-1600V/10	○	—

○ : available — : N/A

Machine Dimensions

Unit : mm

VORTEX e-1250V/8

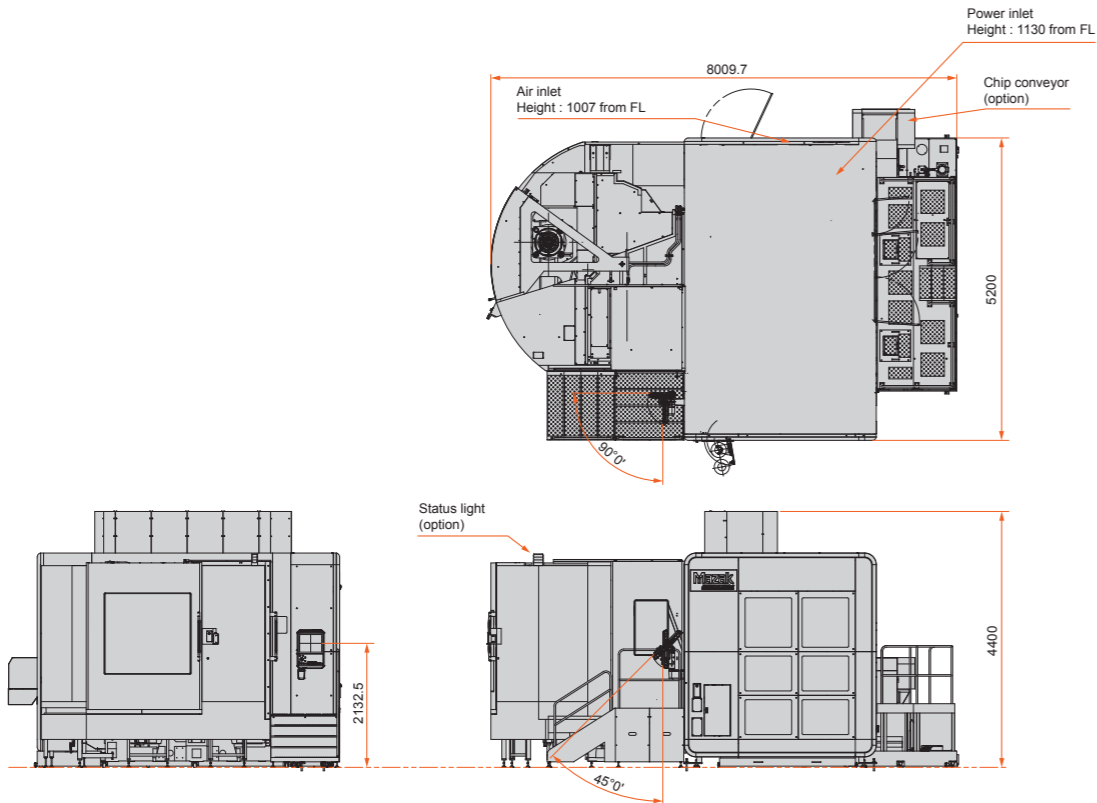

VORTEX e-1600V/10

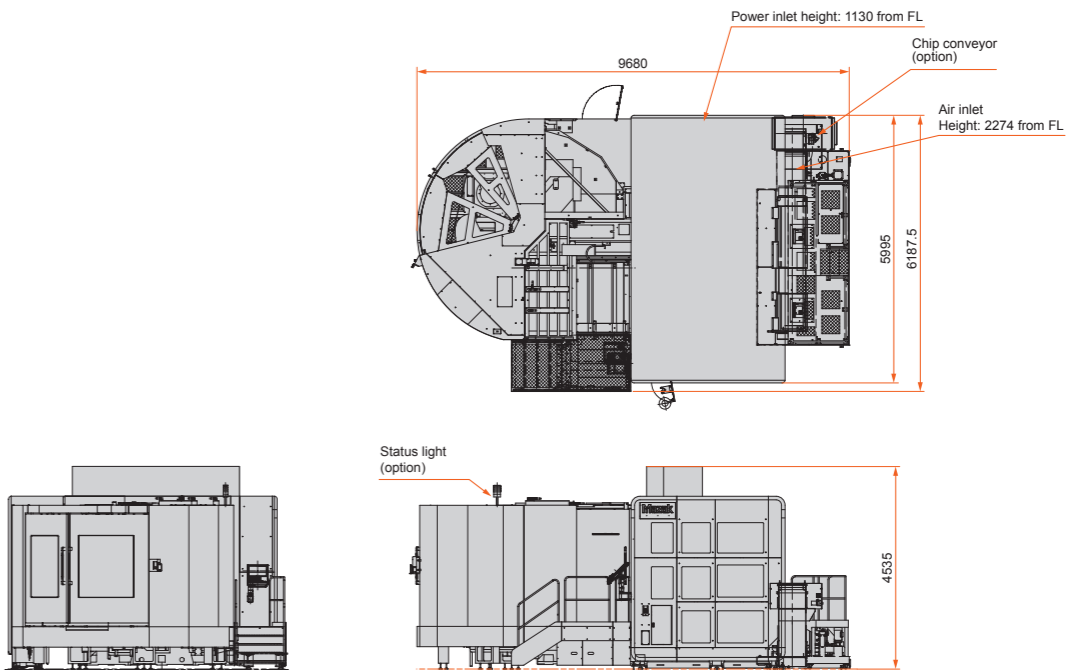

VORTEX e-1250V/8S

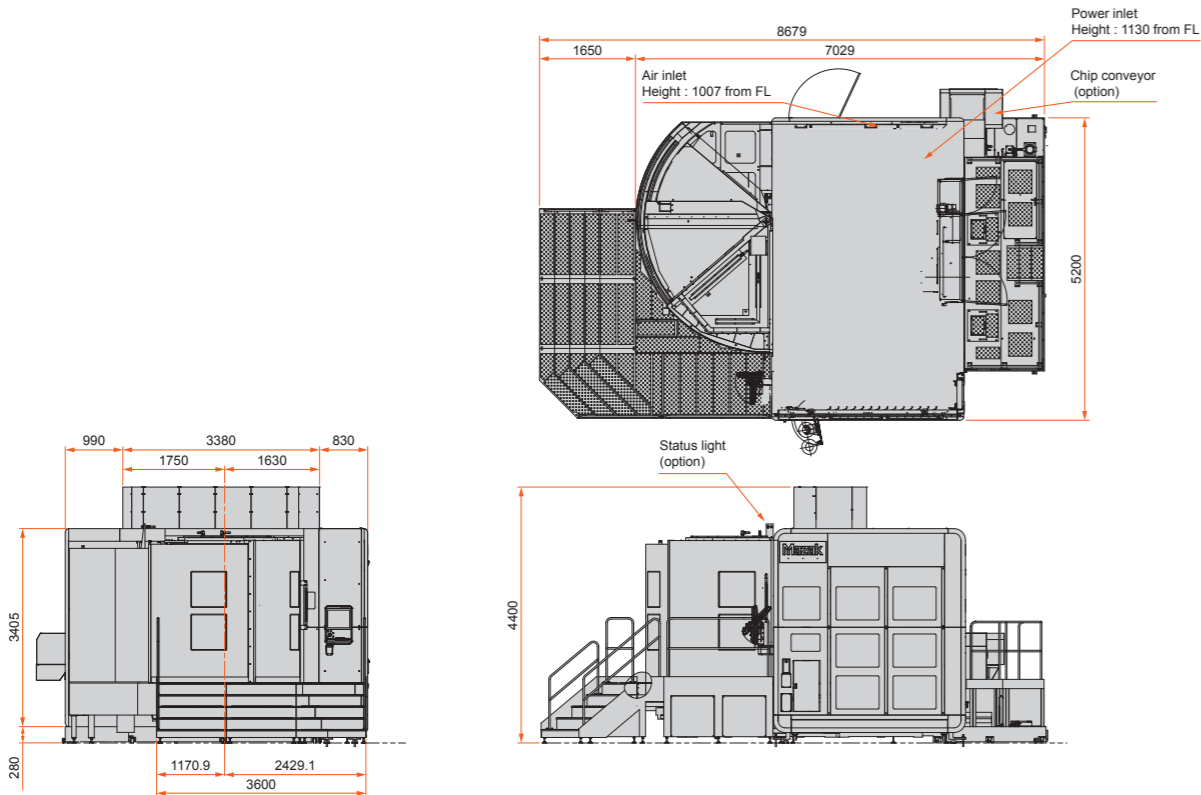

VORTEX e-1600V/10S

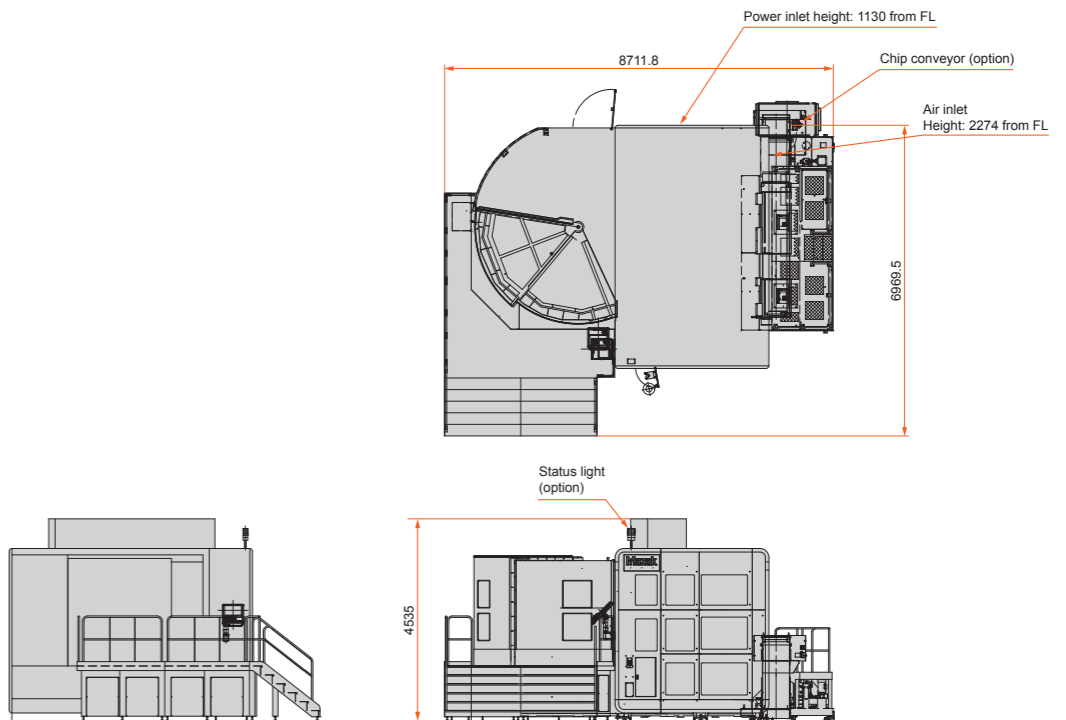

Standard Machine Specifications

		VORTEX e-1250V/8	VORTEX e-1250V/8S
Travel	X-axis (table forward / backward)	1875 mm	
	Y-axis (spindle head travel right / left)	1250 mm	
	Z-axis (spindle head travel up / down)	1345 mm	
	B-axis (spindle head tilt)	150°(-30° ~ + 120°)	
	C-axis (table rotation)	360°(cont.)	
	Distance between B-axis rotation center and pallet center (X-axis at home)	1335 mm	
	Distance between B-axis rotation center and pallet center (X-axis at stroke end)	-540 mm	
	Distance between spindle nose and pallet center (B-axis = +90°) (X-axis at home)	1035 mm	
	Distance between B-axis rotation center and pallet top face**	50 mm ~ 1395 mm	105 mm ~ 1450 mm
	Distance between spindle nose and pallet top face (B-axis=0°)**	-250 mm ~ 1095 mm	-195 mm ~ 1150 mm
Capacity	Max. workpiece size**	ø1450 × 1600 mm	ø1500 × 1655 mm
	Table load capacity (evenly distributed)	2700 kg (Including pallet weight)	4000 kg (Including pallet weight)
Spindle	Max. speed	10000 rpm	
	Spindle taper	No.50	
	Spindle bearing ID	ø100 mm	
	Spindle acceleration	3.1 sec (0 ~ 10000 rpm)	
	Rapid traverse rate (B-axis)	30 rpm	
	Min. indexing angle increment (B-axis)	0.0001°	
	Indexing time (B-axis)	0.7 sec / 90°	
Table	Rapid traverse rate (C-axis)	25 rpm	
	Min. indexing angle increment (C-axis)	0.0001°	
	Indexing time (C-axis)	1.1 sec / 90°	
Feedrate**	Rapid traverse rate (X, Y, Z-axes)	42000 mm/min	
	Max. cutting feedrate (X, Y, Z-axes)	42000 mm/min	
Automatic tool changer	Tool shank	CAT-50	
	Pull stud	ANSI	
	Tool magazine capacity	42	
	Max. tool diameter / length (from gauge line) / max. weight / momentum	ø135 mm / 650 mm / 30 kg / 49 N·m	
	Max. tool diameter with adjacent tool pockets empty	ø260 mm	
Automatic pallet changer	Number of pallets	2	—
	Pallet change time	15 sec	—
	Pallet changer type	Rotary type	—
Motors	Spindle motor (40 % ED / cont. rating)	AC 37 / 30 kW (50 / 40 HP)	
Power requirement	Electrical power supply (40% ED / cont. rating)	113.3 kVA / 123.3 kVA	
	Air supply	1000 L/min (ANR)	
Tank capacity	Coolant tank capacity	1100 L	
Machine size	Machine height (from floor)	4400 mm	
	Floor space requirement	5200 × 8009.7 mm	5200 × 8679 mm
	Machine weight	49500 kg	45000 kg
CNC		MAZATROL SmoothX	
Sound	Equivalent continuous sound pressure level at operator position (depend on equipment options)	less than 80 db (A)	

** With e-1250V/8 : □800 mm tapped pallet, e-1250V/8S : ø1250 mm faceplate with jaws and □1000 mm tapped pallet, e-1250V/8S : ø1000 mm faceplate with jaws

** Limited feedrate with continuous movement

		VORTEX e-1600V/10	VORTEX e-1600V/10S
Travel	X-axis (table forward / backward)	2315 mm	2165 mm
	Y-axis (spindle head travel right / left)	1600 mm	
	Z-axis (spindle head travel up / down)	1345 mm	
	B-axis (spindle head tilt)	150°(-30° ~ + 120°)	
	C-axis (table rotation)	360°(cont.)	
	Distance between B-axis rotation center and pallet center (X-axis at home)	1775 mm	
	Distance between B-axis rotation center and pallet center (X-axis at stroke end)	-540 mm	-390 mm
	Distance between spindle nose and pallet center (B-axis = +90°) (X-axis at home)	1475 mm	
	Distance between B-axis rotation center and pallet top face**	100 mm ~ 1445 mm	169 mm ~ 1514 mm
	Distance between spindle nose and pallet top face (B-axis=0°)**	-200 mm ~ 1145 mm	-131 mm ~ 1214 mm
Capacity	Max. workpiece size**	ø2050 × 1600 mm	ø2300 × 1669 mm
	Table load capacity (evenly distributed)	5000 kg (Including pallet weight)	7000 kg (Including pallet weight)
Spindle	Max. speed	10000 rpm	
	Spindle taper	No.50	
	Spindle bearing ID	ø100 mm	
	Spindle acceleration	3.1sec (0 ~ 10000 rpm)	
	Rapid traverse rate (B-axis)	30 rpm	
	Min. indexing angle increment (B-axis)	0.0001°	
	Indexing time (B-axis)	0.7 sec (90°)	
Table	Rapid traverse rate (C-axis)	20 rpm	
	Min. indexing angle increment (C-axis)	0.0001°	
	Indexing time (C-axis)	1.4 sec / 90°	
Feedrate**	Rapid traverse rate (X, Y, Z-axes)	42000 mm/min	
	Max. cutting feedrate (X, Y, Z-axes)	42000 mm/min	
Automatic tool changer	Tool shank	CAT-50	
	Pull stud	ANSI	
	Tool magazine capacity	42	
	Max. tool diameter / length (from gauge line) / max. weight / momentum	ø135 mm / 650 mm / 30 kg / 49 N·m	
	Max. tool diameter with adjacent tool pockets empty	ø260 mm	
Automatic pallet changer	Number of pallets	2	—
	Pallet change time	25 sec	—
	Pallet changer type	Rotary type	—
Motors	Spindle motor (40 % ED / cont. rating)	AC 37 / 30 kW (50 / 40 HP)	
Power requirement	Electrical power supply (40% ED / cont. rating)	110.7 kVA / 120.6 kVA	
	Air supply	1100 L/min (ANR)	
Tank capacity	Coolant tank capacity	1100 L	
Machine size	Machine height (from floor)	4535 mm	
	Floor space requirement	6187.5 × 9680 mm	6969.5 × 8711.8 mm
	Machine weight	58000 kg	46700 kg
CNC		MAZATROL SmoothX	
Sound	Equivalent continuous sound pressure level at operator position (depend on equipment options)	less than 80 db (A)	

** With e-1600V/10 : □1000 mm tapped pallet (option), e-1600V/10S : ø1400 mm faceplate with jaws (option)

** Limited feedrate with continuous movement

Standard and Optional Equipment

● : Standard ○ : Option — : N/A

		e-1250V/8	e-1250V/8S	e-1600V/10	e-1600V/10S
Spindle	CAT #50 spindle	●	●	●	●
	HSK	○	○	○	○
	CAPTO	○	○	○	○
	Standard specification 10000 rpm	●	●	●	●
	High torque specification 5000 rpm 500 N·m (cont. rating)	○	○	○	○
	High speed specification 15000 rpm 45 kW (cont. rating)*	○	○	○	○
Table	Standard specification NC rotary table contouring torque 3180 N·m	●	●	●	●
	High torque specification NC rotary table contouring torque 5810 N·m	○	○	○	○
Column	Z-axis high column (250 mm)	○	○	—	—
	Z-axis high column (300 mm)	—	—	○	○
Tool magazine	42 tools-rack type tool magazine	●	●	●	●
	84 tools-rack type tool magazine	○	○	○	○
	120 tools-rack type tool magazine	○	○	○	○
	162 tools-rack type tool magazine	○	○	○	○
	180 tools-TOOL HIVE	○	○	○	○
	216 tools-TOOL HIVE	○	○	○	○
	252 tools-TOOL HIVE	○	○	○	○
	288 tools-TOOL HIVE	○	○	○	○
	324 tools-TOOL HIVE	○	○	○	○
360 tools-TOOL HIVE	○	○	○	○	
Pallet changer	Manual pallet rotation at 2PC loading station	●	—	—	—
	Power pallet rotation at 2PC loading station	○	—	●	—
	FMS preparation for 2PC (Pallet can rotate at loading station)	○	—	○	—
	2PC for FMS (Pallet cannot rotate at loading station)	○	—	○	—
Setup	Absolute position detection (linear axes)	●	●	●	●
	Manual pulse generator (cable)	●	●	●	●
	Manual pulse generator (wireless)	○	○	○	○
	Automatic tool length measurement & tool breakage detection	○	○	○	○
	Laser milling tool measurement system (NC4 / air blast)	○	○	○	○
Tool breakage detection	○	○	○	○	

* HSK tool shank
Above specifications are for European market.
Standard and optional equipment vary by market.

● : Standard ○ : Option — : N/A

		e-1250V/8	e-1250V/8S	e-1600V/10	e-1600V/10S
Setup	Preparation for Mazak monitoring system B (RMP-600)	●	●	●	●
	Wireless touch probe (RMP-600)	○	○	○	○
	Tool magazine operation panel	○	○	○	○
	Pull stud with tool ID (#50 Euchner)	○	○	○	○
Automation	Auto power off	●	●	●	●
	Calendar type automatic power on / off and warm-up operation	●	●	●	●
High accuracy	Chiller unit (milling spindle, turning spindle [table], ball screw core cooling)	●	●	●	●
	Ball screw core cooling (X, Y, Z-axes)	●	●	●	●
	Scale feedback (Z-axis)	●	●	●	●
	Scale feedback (X, Y-axes)	○	○	○	○
	Scale feedback (C-axis)	●	●	●	●
	Scale feedback (B-axis)	○	○	○	○
	Hydraulic unit temperature control	○	○	○	○
	Coolant temperature control	○	○	○	○
Coolant / chip disposal	Air through spindle (not available during spindle rotation)	●	●	●	●
	Flood coolant and coolant through spindle 1.5 MPa	●	●	●	●
	Super flow coolant system	○	○	○	○
	Niagara coolant	●	●	●	●
	Oil skimmer (RB-200)	○	○	○	○
	Magnetic plate	○	○	○	○
	Mist collector	○	○	○	○
	Hand held coolant nozzle	○	○	○	○
	Hand held coolant nozzle for pallet changer	○	—	○	—
	Pressure switch for coolant through spindle	○	○	○	○
Secondary filter for coolant (for aluminum)	○	○	○	○	
Chip conveyor (side discharge, CONSEP)	○	○	○	○	
Safety equipment	Operator door interlock	●	●	●	●
	Overload detection	○	○	○	○
	Hydraulic pressure interlock	○	○	○	○

	MAZATROL	EIA
Number of controlled axes	Simultaneous 2 ~ 4 axes	Simultaneous 2 ~ 4 axes, Simultaneous 5 axes*
Least input increment	0.0001 mm, 0.00001°, 0.0001 deg	
High speed, high precision control	Shape error designation, Smooth corner control, Rapid traverse overlap, Rotational-shape correction	Shape error designation, Smooth corner control, Rapid traverse overlap, Rotational-shape correction, High-speed machining mode, High-speed smoothing control function, 5-axis spline*
Interpolation	Positioning (Linear interpolation), Positioning (Independent interpolation), Linear interpolation, Circular interpolation, Cylindrical coordinate interpolation, Polar coordinate interpolation, Synchronized milling spindle tapping*	Positioning (Linear interpolation), Positioning (Independent interpolation), Linear interpolation, Circular interpolation, Spiral interpolation, Helical interpolation, Cylindrical coordinate interpolation*, Fine spline interpolation*, NURBS interpolation*, Polar coordinate interpolation*, Synchronized milling spindle tapping*
Feedrate	Rapid traverse, Cutting feed, Cutting feed (per minute), Cutting feed (per revolution), Dwell (specified time, specified number of rotation), Rapid traverse override, Cutting feed override, G0 speed variable control, Feedrate clamp, Variable acceleration / deceleration control, Constant control for G0 tilting*	Rapid traverse, Cutting feed, Cutting feed (per minute), Cutting feed (per revolution), Inverse time feed, Dwell (specified time, specified number of rotation), Rapid traverse override, Cutting feed override, G0 speed variable control, Feedrate clamp, Time constant changing for G1, Variable acceleration / deceleration control, Constant control for G0 tilting*
Program registration	Max. number of programs : 960, Program storage : 2 MB, Program storage expansion : 8 MB*, Program storage expansion : 32 MB*	
Control display	Display : 19" touch panel, Resolution : SXGA	
Spindle functions	S code output, Spindle speed clamp, Spindle speed override, Spindle speed reaching detection, Multiple position orient, Constant surface speed, Spindle speed command with decimal digits, Synchronized spindle control, Max. speed control for spindle	
Tool functions	Tool offset pairs : 4000, T code output for tool number, Tool life monitoring (time), Tool life monitoring (number of machined workpieces)	Tool offset pairs : 4000, T code output for tool number, T code output for group number, Tool life monitoring (time), Tool life monitoring (number of machined workpieces)
Miscellaneous functions	M code output, Simultaneous output of multiple M codes	
Tool offset functions	Tool position offset, Tool length offset, Tool diameter / tool nose R offset, Tool wear offset	
Coordinate system	Machine coordinate system, Work coordinate system, Local coordinate system, Additional work coordinates (300 set)	
Machine functions	Rotary axis pre-filter, Angled surface cutting, Hobbing*, Hobbing II*, Shaping function*, Dynamic compensation II*, Tool nose point control*, Tool diameter compensation for 5-axis machining*, Workpiece positioning error compensation*	
Machine compensation	G0 / G1 independent backlash compensation, Pitch error compensation, Geometric deviation compensation, Volumetric compensation*	
Protection functions	Emergency stop, Interlock, Stroke check before travelling, Retraction function for the vertical axes, INTELLIGENT SAFETY SHIELD (manual mode), INTELLIGENT SAFETY SHIELD (automatic mode), MAZAK VOICE ADVISER	
Automatic operation mode	Memory operation	Memory operation, Tape operation, MDI operation, Ethernet operation*
Automatic operation mode	Optional stop, Dry run, Automatic handle control, MDI control, TPS, Restart, Machine lock	Optional block skip, Optional stop, Dry run, Automatic handle control, MDI control, TPS, Restart, Restart 2, Collation stop, Machine lock
Manual measuring functions	Tool length and tip teach, Touch sensor coordinates measurement, Workpiece offset measurement, WPC coordinate measurement, Measurement on machine	Tool length and tip teach, Tool offset teach, Touch sensor coordinates measurement, Workpiece offset measurement, WPC coordinate measurement, Measurement on machine
Automatic measuring functions	WPC coordinate measurement, Automatic tool length measurement, Touch sensor orientation confirmation, Tool breakage detection, External tool breakage detection*	Automatic tool length measurement, Touch sensor orientation confirmation, Tool breakage detection, External tool breakage detection*
MDI measurement	Partial auto tool length measurement, Auto tool length measurement, Coordinate measurement	
Interface	PROFIBUS-DP*, EtherNET I/P*, CC-Link*, USB	
Card interface	SD card interface	
EtherNet	10 M / 100 M / 1 Gbps	

* Option

Environmentally friendly



Designed with environmental considerations

The environment and our impact on natural surroundings have always been important concerns of Yamazaki Mazak. This is shown by the fact that all factories in Japan where Mazak machine tools are produced are ISO 14001 certified, an international standard confirming that the operation of our production facilities does not adversely affect air, water, or land.

Environmental considerations

Reduction of energy consumption

Worklights in machine and CNC screen backlight are automatically turned off after preregistered period of inactivity. The optional chip conveyor automatically stops operation at the end of workpiece machining.

Reduction of lubrication consumption

Compared to a conventional oil system, the grease lubrication system has significantly lower lubricant consumption.

Extended service life of coolant

Grease lubrication eliminates tramp oil in the coolant which prevents coolant deterioration and reduces coolant disposal frequency.

Energy Dashboard OPTION

Energy consumption displayed on graph

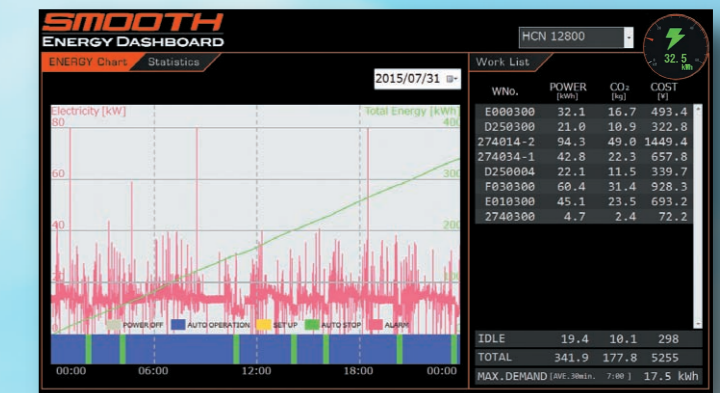

Current energy consumption on process screen



Analysis of energy consumption

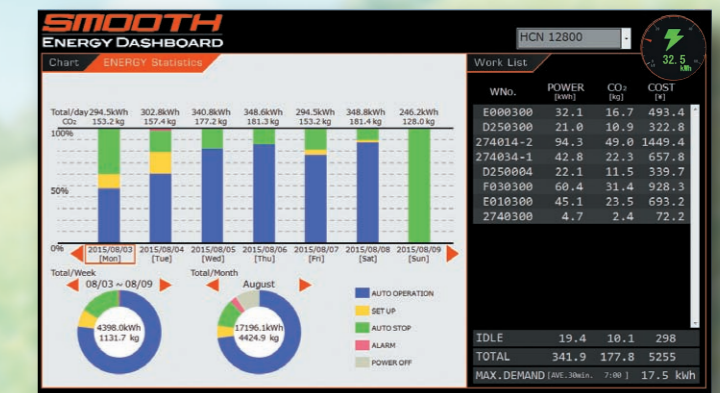

* Requires optional power meter